

F

SERIES

QUARTER-TURN PNEUMATIC & FLUID POWER ACTUATOR – PRODUCT BULLETIN

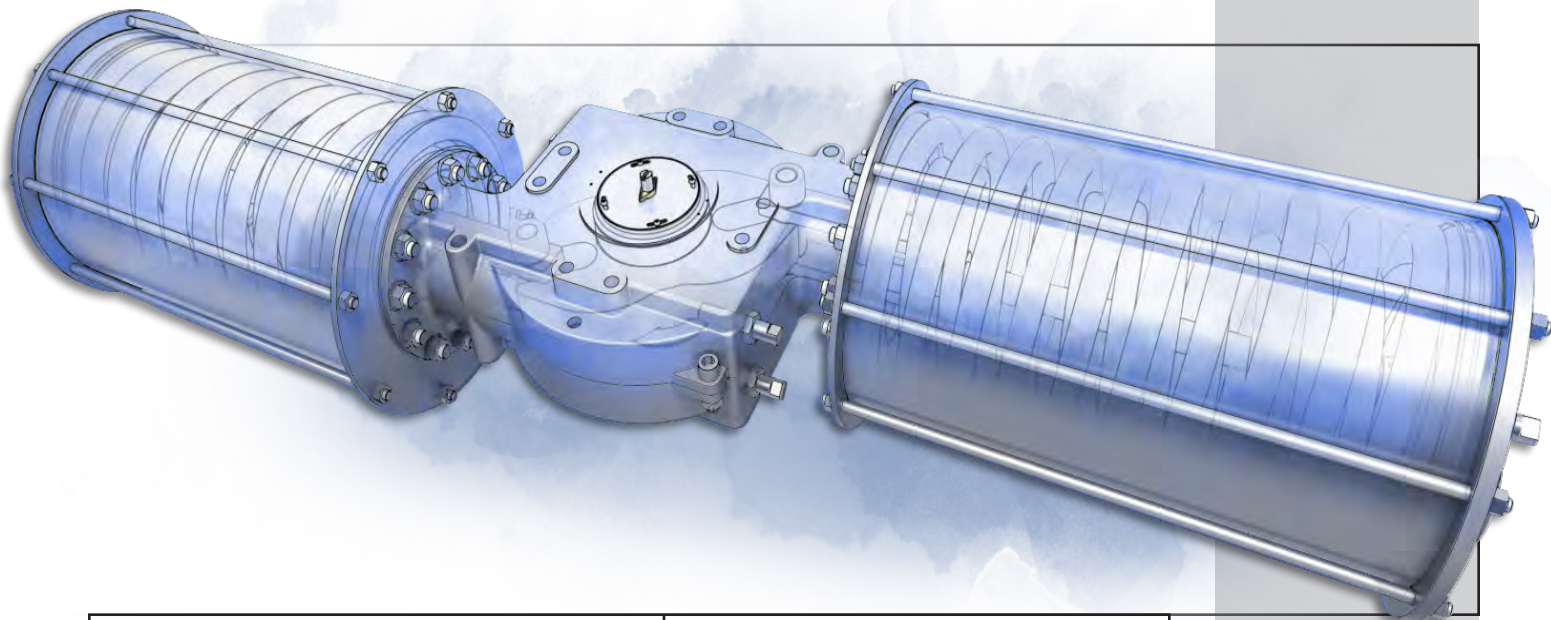

Output Torques to 500,000 in-lb (56,492 Nm)
Temperatures from -76°F to 450°F (-60°C to 232°C)

Ductile Iron or Stainless Steel Construction
Double-Acting and Spring-Return Models

HIGH CYCLE LIFE, HIGH SPEED, HIGH RELIABILITY

The Leader in Actuator Technology



F

SERIES

QTRCO, INC. PRODUCT BULLETIN

TABLE OF CONTENTS

OPERATION AND PIPING _____	P 4
DIMENSIONS _____	P 6
WEIGHTS _____	P 14
PERFORMANCE DATA _____	P 16
TORQUE DATA _____	P 17
PARTS DIAGRAM & MATERIALS OF CONSTRUCTION _____	P 36
ENGINEERING STRING _____	P 38



OPERATION AND PIPING

F2 series actuators may be operated with instrument air, hydraulic fluid, water, or other power gases and fluids. Always ensure that the materials of construction are compatible with the application and that the pressure does not exceed the maximum allowable.

Environmental Ingress Protection (Submerged Service)

F2-Series actuators are capable of achieving IP67 and IP68 ratings for continuous immersion up to a depth of 10 meters. Double acting versions may achieve the IP67 and IP68 ratings by tubing in the normal manner and then plugging the actuator body ports using appropriate thread sealant. For spring return actuators, the IP67 and IP68 ratings may be achieved by one of three methods:

1. The actuator body ports may be fitted with filters or strainers, allowing fluid to enter the actuator body. This method may only be used if the submersion fluid is compatible with the actuator materials of construction and lubricants. Because the fluid will not adversely affect actuator operation, IP68 requirements will still be met. This method may reduce stroke speed depending on the flow capacity of the filter.
2. The actuator breather port may be plugged using appropriate thread sealant. This method may slightly reduce air torque output due to compression of the air trapped in the actuator body.
3. The actuator breather port may be piped to a non-submerged location and fitted with a filter or strainer device.

For the highest level of safety, QTRCO recommends method 3: piping the breather port to a non-submerged location. For F2-Series actuators, the IP67 and IP68 ratings must be requested at the time of order.

All QTRCO actuators are shipped in the Fail-Close or Left-Hand orientation unless ordered as Fail-Open or Right-Hand. The mode of operation may be reversed in the field simply by turning the actuator top-side down.

1. **Fail-Close (Left-Hand):** pressure on the end cap port(s) pushes the piston(s) inward resulting in counterclockwise rotation. Exhaustion of pressure allows springs to push outward on the piston and cause clockwise rotation.
2. **Fail-Open (Right-Hand):** pressure on the end cap port(s) pushes the piston(s) inward resulting in clockwise rotation. Exhaustion of pressure allows springs push outward on the piston and cause counterclockwise rotation.
3. **Double Acting (Left-Hand):** pressure on the end cap port(s) pushes the piston(s) inward and causes counterclockwise rotation. Pressure on the body port pushes outward on the piston(s) and cause clockwise rotation.
4. **Double Acting (Right-Hand):** pressure on the end cap port(s) pushes the piston(s) inward and causes clockwise rotation. Pressure on the body port pushes outward on the piston(s) and cause counterclockwise rotation.

PIPING GUIDELINES:

1. Both endcap pressure ports P1 and P2 must be pressurized simultaneously for proper operation.
2. Pressure ports P1 and P2 are typically connected together and powered by a single pathway.
3. For all Double Acting (DA) models, both base plate pressure ports P3 and P4 must be pressurized simultaneously for proper operation. These ports are not present on SR models.
4. Pressure ports P3 and P4 are typically connected together and powered by a single pathway. Body ports P5 and P6 (shown in dimensional drawing on page 6) are breather vents which should be fitted with a strainer on SR models and may be plugged on DA models.

SPRING RETURN (SR)

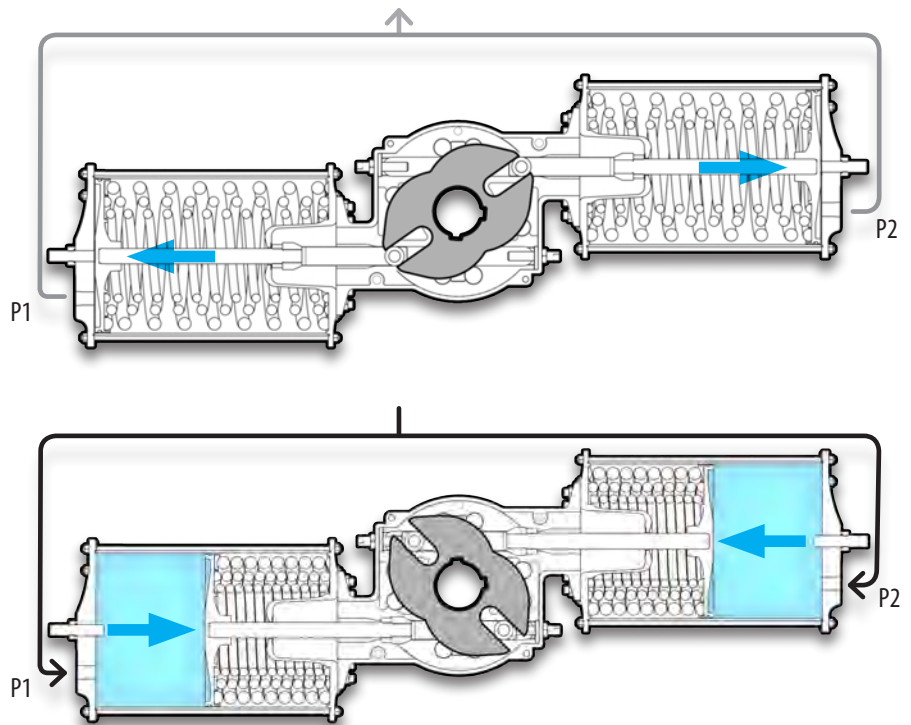

DOUBLE ACTING (DA)

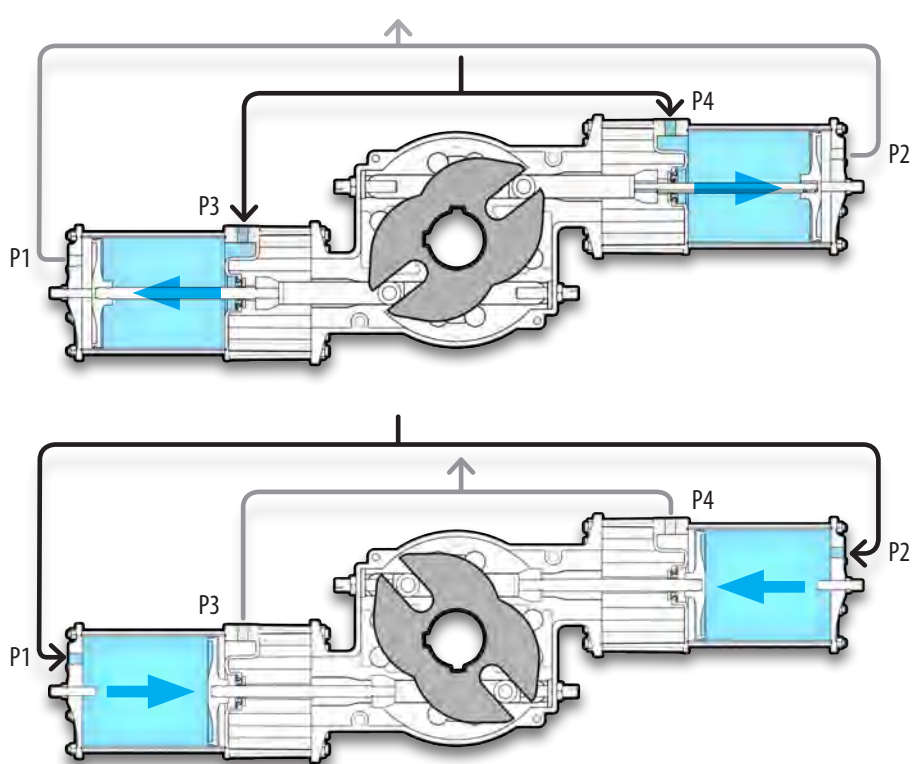

Dimensions and Technical Data

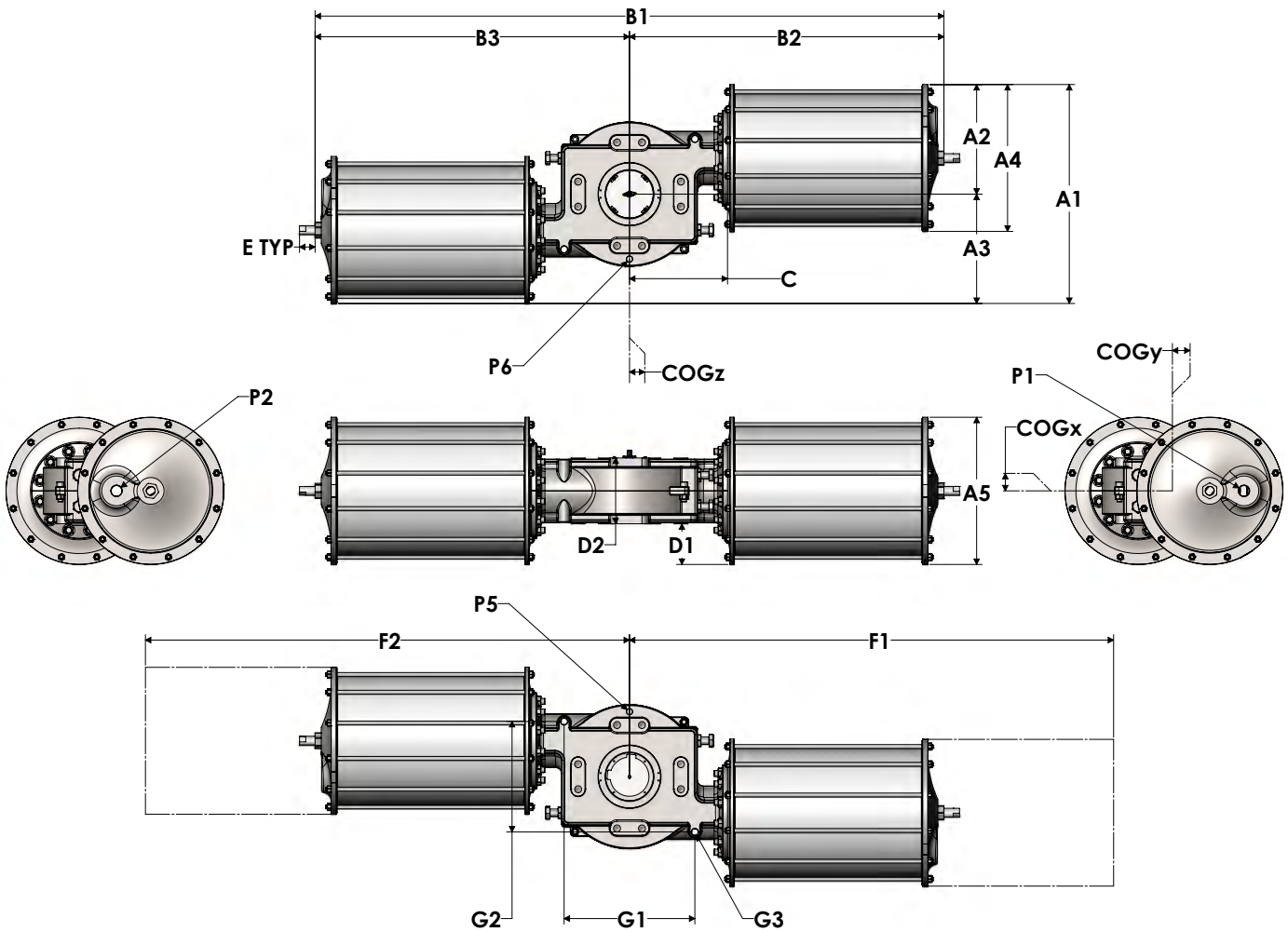

Dimensions and Technical Data

NAMUR TOP HAT DIMENSIONS

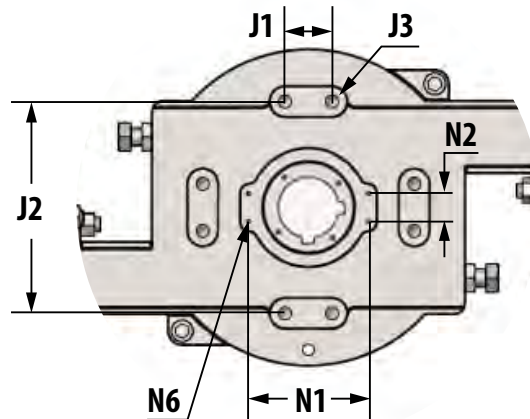
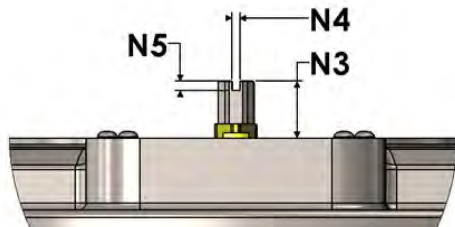

MOUNTING DIMENSIONS

2075

2100 AND 2150

SIZES 2200 THROUGH 2575

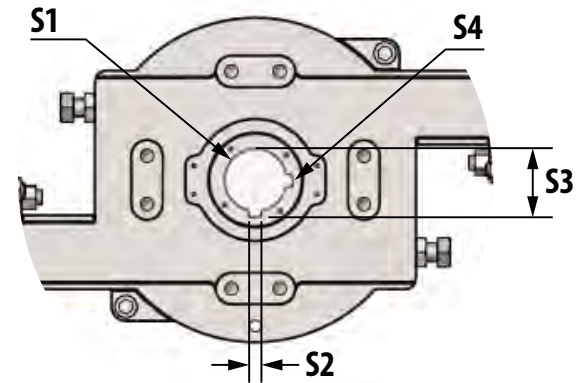
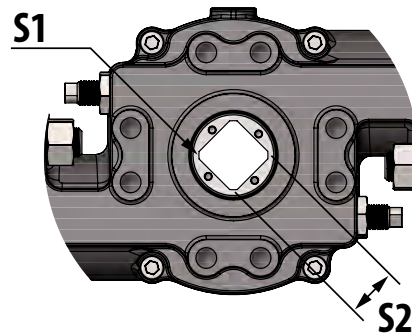
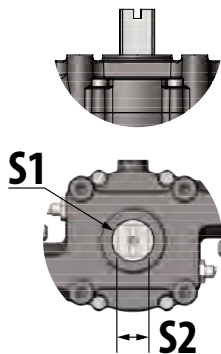

DIMENSIONS BELOW FOR DOUBLE ACTING MODELS ONLY

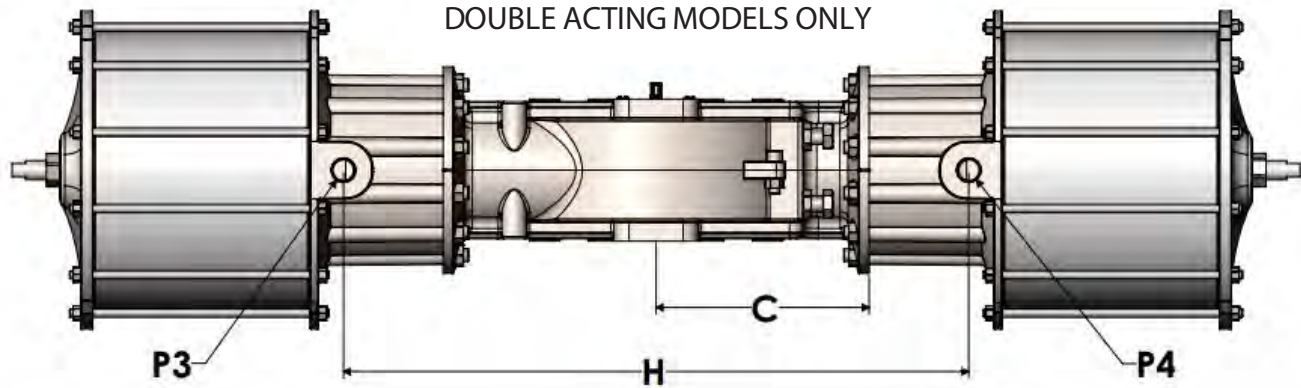

Dimensions (Imperial, Inches)

ENVELOPE DIMENSIONS		2075			2100				2150			
		DA-C030	SR-C030	SR-C040	DA-C030	DA-C040	SR-C040	SR-C050	DA-C040	DA-C050	SR-C050	SR-C060
Width Total	A1	4.88	4.88	6.05	5.38	6.55	6.55	7.54	7.55	8.54	8.54	9.56
Width Side 1	A2	2.44	2.44	3.02	2.69	3.28	3.27	3.77	3.77	4.27	4.27	4.78
Width Side 2	A3	2.44	2.44	3.02	2.69	3.28	3.27	3.77	3.77	4.27	4.27	4.78
Width Cylinder	A4	3.38	3.38	4.55	3.38	4.55	4.55	5.54	4.55	5.54	5.54	6.56
Height Cylinder	A5	3.38	3.38	4.55	3.38	4.55	4.55	5.54	4.55	5.54	5.54	6.56
Length Total	B1	15.872	19.00	19.40	18.40	19.08	22.07	22.61	24.45	25.25	28.98	29.58
Length Side 1	B2	7.94	9.50	9.70	9.20	9.54	11.04	11.30	12.23	12.63	14.49	14.79
Length Side 2	B3	7.94	9.50	9.70	9.20	9.54	11.04	11.30	12.23	12.63	14.49	14.79
Flange Distance	C1	8.12	5.91	5.91	8.65	9.46	6.88	6.88	12.42	12.41	9.13	9.14
Max Bracket Width	C2	5.56	5.56	5.56	6.44	6.44	6.44	6.44	8.69	8.69	8.69	8.69
Flange Depth	D1	0.51	0.51	1.01	0.33	0.83	0.83	1.33	0.68	1.18	1.18	1.68
Body Depth	D2	2.49	2.49	2.49	2.83	2.83	2.83	2.83	3.14	3.14	3.14	3.14
Stop Extension	E TYP	0.47	0.47	0.47	0.71	0.63	0.63	0.71	0.66	0.72	0.72	0.66
Maint Clearance	F1	11	15	15	13	13	17	17	17	17	23	23
Maint Clearance	F2	11	15	15	13	13	17	17	17	17	23	23
Lifting Eye Dim X	G1											
Lifting Eye Dim Y	G2											
Lifting Eye Diameter	G3											
P3 - P4 Distance	H	7.8			9.1	9.0			12.0	12.1		

MOUNTING PATTERN

Pattern X	J1	4 BOLT MOUNTING PATTERN (3.5 INCH BCD)			0.75	0.75	0.75	0.75	1.25	1.25	1.25	1.25
Pattern Y	J2				3.31	3.31	3.31	3.31	4.88	4.88	4.88	4.88
Thread	J3	M8-1.25	M8-1.25	M8-1.25	M10-1.5	M10-1.5	M10-1.5	M10-1.5	M12-1.75	M12-1.75	M12-1.75	M12-1.75
Thread Depth		0.47	0.47	0.47	0.50	0.50	0.50	0.50	0.63	0.63	0.63	0.63

ACCESSORY PATTERN Mounting and accessory patterns are identical on both sides.

Length	N1											
Width	N2											
Height	N3	0.984	0.984	0.984	0.894	0.894	0.894	0.894	0.894	0.894	0.894	0.894
Slot Width	N4	0.157	0.157	0.157	0.157	0.157	0.157	0.157	0.157	0.157	0.157	0.157
Slot Depth	N5	0.197	0.197	0.197	0.197	0.197	0.197	0.197	0.197	0.197	0.197	0.197
Thread	N6											
Thread Depth												

DRIVE DIMENSIONS

Shaft Diameter	S1	0.982	0.982	0.982	1.100	1.100	1.100	1.100	1.652	1.652	1.652	1.652
Square Drive Size	S2	0.746	0.746	0.746	0.864	0.864	0.864	0.864	1.258	1.258	1.258	1.258
Shaft Depth/Height		0.984	0.984	0.984	1.142	1.142	1.142	1.142	1.693	1.693	1.693	1.693

CENTER OF GRAVITY

COGx		0.0	0.0	0.0	0.00	0.00	0.00	0.00	0.00	0.00	0.00	0.00
COGy		0.0	0.0	0.0	0.01	0.01	0.01	0.01	0.01	0.01	0.01	0.01
COGz		-0.01	-0.01	-0.01	0.00	0.00	0.00	0.00	0.00	0.00	-0.01	-0.01

Dimensions (Metric, Millimeters)

ENVELOPE DIMENSIONS		2075			2100				2150			
		DA-C030	SR-C030	SR-C040	DA-C030	DA-C040	SR-C040	SR-C050	DA-C040	DA-C050	SR-C050	SR-C060
Width Total	A1	124.0	124.0	153.7	136.7	166.4	166.4	191.5	191.8	216.9	216.9	242.8
Width Side 1	A2	62.0	62.0	76.7	68.3	83.3	83.1	95.8	95.8	108.5	108.5	121.4
Width Side 2	A3	62.0	62.0	76.7	68.3	83.3	83.1	95.8	95.8	108.5	108.5	121.4
Width Cylinder	A4	85.9	85.9	115.6	85.9	115.6	115.6	140.7	115.6	140.7	140.7	166.6
Height Cylinder	A5	85.9	85.9	115.6	85.9	115.6	115.6	140.7	115.6	140.7	140.7	166.6
Length Total	B1	403.1	482.6	492.8	467.4	484.6	560.6	574.3	621.0	641.4	736.1	751.3
Length Side 1	B2	201.7	241.3	246.4	233.7	242.3	280.4	287.0	310.6	320.8	368.0	375.7
Length Side 2	B3	201.7	241.3	246.4	233.7	242.3	280.4	287.0	310.6	320.8	368.0	375.7
Flange Distance	C1	206.2	150.1	150.1	219.7	240.3	174.8	174.8	315.5	315.2	231.9	232.2
Max Bracket Width	C2	141.2	141.2	141.2	163.6	163.6	163.6	163.6	220.7	220.7	220.7	220.7
Flange Depth	D1	13.0	13.0	25.7	8.4	21.1	21.1	33.8	17.3	30.0	30.0	42.7
Body Depth	D2	63.2	63.2	63.2	71.9	71.9	71.9	71.9	79.8	79.8	79.8	79.8
Stop Extension	E TYP	11.9	11.9	11.9	18.0	16.0	16.0	18.0	16.8	18.3	18.3	16.8
Maint Clearance	F1	279.4	381.0	381.0	330.2	330.2	431.8	431.8	431.8	431.8	584.2	584.2
Maint Clearance	F2	279.4	381.0	381.0	330.2	330.2	431.8	431.8	431.8	431.8	584.2	584.2
Lifting Eye Dim X	G1											
Lifting Eye Dim Y	G2											
Lifting Eye Diameter	G3											
P3 - P4 Distance	H	198.1			231.1	228.6			304.8	307.3		

MOUNTING PATTERN

Pattern X	J1	4 BOLT MOUNTING PATTERN ON A 88.9 mm BCD			19.1	19.1	19.1	19.1	31.8	31.8	31.8	31.8
Pattern Y	J2				84.1	84.1	84.1	84.1	124.0	124.0	124.0	124.0
Thread	J3	M8-1.25	M8-1.25	M8-1.25	M10-1.5	M10-1.5	M10-1.5	M10-1.5	M12-1.75	M12-1.75	M12-1.75	M12-1.75
Thread Depth		11.9	11.9	11.9	12.7	12.7	12.7	12.7	16.0	16.0	16.0	16.0

ACCESSORY PATTERN Mounting and accessory patterns are identical on both sides.

Length	N1											
Width	N2											
Height	N3	25.0	25.0	25.0	22.7	22.7	22.7	22.7	22.7	22.7	22.7	22.7
Slot Width	N4	4.0	4.0	4.0	4.0	4.0	4.0	4.0	4.0	4.0	4.0	4.0
Slot Depth	N5	5.0	5.0	5.0	5.0	5.0	5.0	5.0	5.0	5.0	5.0	5.0
Thread	N6											
Thread Depth												

DRIVE DIMENSIONS

Shaft Diameter	S1	24.95	24.95	24.95	27.95	27.95	27.95	27.95	41.95	41.95	41.95	41.95
Square Drive Size	S2	18.95	18.95	18.95	21.95	21.95	21.95	21.95	31.95	31.95	31.95	31.95
Shaft Depth/Height	S3	25.00	25.00	25.00	29.00	29.00	29.00	29.00	43.00	43.00	43.00	43.00

CENTER OF GRAVITY

COGx		0.0	0.0	0.0	0.0	0.0	0.0	0.0	0.0	0.0	0.0	0.0
COGy		0.0	0.0	0.0	0.3	0.3	0.3	0.3	0.3	0.3	0.3	0.3
COGz		-0.3	-0.3	-0.3	0.0	0.0	0.0	0.0	0.0	0.0	-0.3	-0.3

Dimensions (Imperial, Inches)

ENVELOPE DIMENSIONS		2200		2250				2300			
		DA06	SR06	DA06	DA08	SR08	SR10	DA08	DA10	DA12	SR12
Width Total	A1	10.50	10.50	10.50	13.19	13.19	17.50	14.80	18.50	20.70	20.80
Width Side 1	A2	5.25	5.25	5.25	6.59	6.59	8.75	7.40	9.25	10.35	10.40
Width Side 2	A3	5.25	5.25	5.25	6.59	6.59	8.75	7.40	9.25	10.35	10.40
Width Cylinder	A4	6.50	6.50	6.50	8.75	8.75	12.50	8.75	12.50	14.80	14.80
Height Cylinder	A5	6.50	6.50	6.50	8.75	8.75	12.50	8.75	12.50	14.80	14.80
Length Total	B1	31.40	37.20	40.20	41.40	43.40	45.00	47.00	48.50	49.00	58.00
Length Side 1	B2	15.70	18.60	20.10	20.70	21.70	22.50	23.50	24.20	24.50	29.00
Length Side 2	B3	15.70	18.60	20.10	20.70	21.70	22.50	23.50	24.20	24.50	29.00
Flange Distance	C1	6.38	6.38	7.41	7.41	7.41	7.41	10.19	12.50	12.00	10.19
Max Bracket Width	C2	9.34	9.34	13.83	13.83	13.83	13.83	19.09	19.09	19.09	19.09
Flange Depth	D1	1.22	1.22	0.05	1.57	1.44	3.44	1.20	3.07	4.21	4.21
Body Depth	D2	4.10	4.10	5.60	5.60	5.60	5.60	6.40	6.40	6.40	6.40
Stop Extension	E TYP	0.66	0.72	0.66	0.43	0.43	0.86	0.80	1.30	1.30	1.15
Maint Clearance	F1	23.00	30.00	28.00	29.00	34.00	35.00	34.00	33.00	33.00	45.00
Maint Clearance	F2	23.00	30.00	28.00	29.00	34.00	35.00	34.00	33.00	33.00	45.00
Lifting Eye Dim X	G1										
Lifting Eye Dim Y	G2										
Lifting Eye Diameter	G3										
P3 - P4 Distance	H	14.10		20.00	19.50			22.80	25.10	24.10	

MOUNTING PATTERN

Pattern X	J1	1.75	1.75	2.00	2.00	2.00	2.00	2.00	2.00	2.00	2.00
Pattern Y	J2	6.50	6.50	8.00	8.00	8.00	8.00	9.00	9.00	9.00	9.00
Thread Type	J3	M12-1.75	M12-1.75	M16-2	M16-2	M16-2	M16-2	M16-2	M16-2	M16-2	M16-2
Thread Depth		0.75	0.75	0.75	0.75	0.75	0.75	0.75	0.75	0.75	0.75

ACCESSORY PATTERN The namur slotted drive can be moved to the opposite side for field reversibility

Length	N1	5.118	5.118	5.118	5.118	5.118	5.118	5.118	5.118	5.118	5.118
Width	N2	1.181	1.181	1.181	1.181	1.181	1.181	1.181	1.181	1.181	1.181
Height	N3	1.181	1.181	1.181	1.181	1.181	1.181	1.181	1.181	1.181	1.181
Slot Width	N4	0.157	0.157	0.157	0.157	0.157	0.157	0.157	0.157	0.157	0.157
Slot Depth	N5	0.197	0.197	0.197	0.197	0.197	0.197	0.197	0.197	0.197	0.197
Thread	N6	M5-0.8	M5-0.8	M5-0.8	M5-0.8	M5-0.8	M5-0.8	M5-0.8	M5-0.8	M5-0.8	M5-0.8
Thread Depth		0.38	0.38	0.38	0.38	0.38	0.38	0.38	0.38	0.38	0.38

DRIVE DIMENSIONS

Shafts have two keyways 90 degrees apart. Only one keyway is required to transmit torque.
Max engagement shown with tophat. Removal of tophat allows shaft to extend through the actuator bore.

Shaft Bore	S1	2.000	2.000	2.000	2.000	2.000	2.000	2.500	2.500	2.500	2.500
Key Width	S2	0.3125	0.3125	0.375	0.375	0.375	0.375	0.500	0.500	0.500	0.500
Female Key Distance	S3	2.147	2.147	2.174	2.174	2.174	2.174	2.729	2.729	2.729	2.729
Key Corner Radius	S4	0.00	0.00	0.00	0.00	0.00	0.00	0.00	0.00	0.00	0.00
Shaft Depth		3.63	3.63	5.13	5.13	5.13	5.13	5.88	5.88	5.88	5.88

CENTER OF GRAVITY

COGx		0.00	0.00	0.00	0.00	0.00	0.00	0.00	0.00	0.00	0.00
COGy		0.00	0.00	0.00	0.00	0.00	0.03	0.00	0.05	0.13	0.03
COGz		0.00	0.00	0.00	0.00	0.00	0.00	0.00	0.00	0.00	0.00

Dimensions (Metric, Millimeters)

ENVELOPE DIMENSIONS		2200		2250				2300			
		DA06	SR06	DA06	DA08	SR08	SR10	DA08	DA10	DA12	SR12
Width Total	A1	266.7	266.7	266.7	334.9	334.9	444.5	375.9	469.9	525.8	528.3
Width Side 1	A2	133.4	133.4	133.4	167.4	167.4	222.3	188.0	235.0	262.9	264.2
Width Side 2	A3	133.4	133.4	133.4	167.4	167.4	222.3	188.0	235.0	262.9	264.2
Width Cylinder	A4	165.1	165.1	165.1	222.3	222.3	317.5	222.3	317.5	375.9	375.9
Height Cylinder	A5	165.1	165.1	165.1	222.3	222.3	317.5	222.3	317.5	375.9	375.9
Length Total	B1	797.6	944.9	1021.1	1051.6	1102.4	1143.0	1193.8	1231.9	1244.6	1473.2
Length Side 1	B2	398.8	472.4	510.5	525.8	551.2	571.5	596.9	614.7	622.3	736.6
Length Side 2	B3	398.8	472.4	510.5	525.8	551.2	571.5	596.9	614.7	622.3	736.6
Flange Distance	C1	161.9	161.9	188.1	188.1	188.1	188.1	258.8	317.5	304.8	258.8
Max Bracket Width	C2	237.2	237.2	351.3	351.3	351.3	351.3	484.9	484.9	484.9	484.9
Flange Depth	D1	31.0	31.0	1.1	39.9	36.6	87.4	30.5	78.0	106.9	106.9
Body Depth	D2	104.1	104.1	142.2	142.2	142.2	142.2	162.6	162.6	162.6	162.6
Stop Extension	E TYP	16.6	18.3	16.6	10.9	10.9	21.8	20.3	33.0	33.0	29.2
Maint Clearance	F1	576.6	750.8	720.6	748.0	870.0	893.6	851.9	831.3	843.3	1148.1
Maint Clearance	F2	576.6	750.8	720.6	748.0	870.0	893.6	851.9	831.3	843.3	1148.1
Lifting Eye Dim X	G1										
Lifting Eye Dim Y	G2										
Lifting Eye Diameter	G3										
P3 - P4 Distance	H	358.1		508.0	495.3			579.1	637.5	612.1	

MOUNTING PATTERN

Pattern X	J1	44.45	44.45	50.80	50.80	50.80	50.80	50.80	50.80	50.80	50.80
Pattern Y	J2	165.10	165.10	203.20	203.20	203.20	203.20	228.60	228.60	228.60	228.60
Thread Type	J3	M12-1.75	M12-1.75	M16-2	M16-2	M16-2	M16-2	M16-2	M16-2	M16-2	M16-2
Thread Depth		19.05	19.05	19.05	19.05	19.05	19.05	19.05	19.05	19.05	19.05

ACCESSORY PATTERN The namur slotted drive can be moved to the opposite side for field reversibility

Length	N1	130	130	130	130	130	130	130	130	130	130
Width	N2	30	30	30	30	30	30	30	30	30	30
Height	N3	30	30	30	30	30	30	30	30	30	30
Slot Width	N4	4	4	4	4	4	4	4	4	4	4
Slot Depth	N5	5	5	5	5	5	5	5	5	5	5
Thread	N6	M5-0.8	M5-0.8	M5-0.8	M5-0.8	M5-0.8	M5-0.8	M5-0.8	M5-0.8	M5-0.8	M5-0.8
Thread Depth		9.5	9.5	9.5	9.5	9.5	9.5	9.5	9.5	9.5	9.5

DRIVE DIMENSIONS

Shafts have two keyways 90 degrees apart. Only one keyway is required to transmit torque.
Max engagement shown with tophat. Removal of tophat allows shaft to extend through the actuator bore.

Shaft Bore	S1	50.80	50.80	50.80	50.80	50.80	50.80	63.50	63.50	63.50	63.50
Key Width	S2	7.937	7.937	9.53	9.53	9.53	9.53	12.70	12.70	12.70	12.70
Female Key Distance	S3	54.53	54.53	55.22	55.22	55.22	55.22	69.32	69.32	69.32	69.32
Key Corner Radius	S4	0.00	0.00	0.00	0.00	0.00	0.00	0.00	0.00	0.00	0.00
Shaft Depth		92	92	130	130	130	130	149	149	149	149

CENTER OF GRAVITY

COGx		0.00	0.00	0.00	0.00	0.00	0.00	0.00	0.00	0.00	0.00
COGy		0.00	0.00	0.00	0.00	0.00	0.76	0.00	1.27	3.30	0.76
COGz		0.00	0.00	0.00	0.00	0.00	0.00	0.00	0.00	0.00	0.00

Dimensions (Imperial, Inches)

ENVELOPE DIMENSIONS		2375			2488				2575				
		DA10	DA12	SR16	DA12	DA16	SR16	SR20	DA12	DA16	DA20	SR20	SR24
Width Total	A1	20.25	22.30	26.50	24.20	28.50	28.50	33.20	26.75	30.22	34.96	35.00	39.00
Width Side 1	A2	10.13	11.15	13.25	12.10	14.25	14.25	16.60	13.375	15.11	17.48	17.50	19.50
Width Side 2	A3	10.13	11.15	13.25	12.10	14.25	14.25	16.60	13.375	15.11	17.48	17.50	19.50
Width Cylinder	A4	12.70	14.80	19.00	14.80	19.00	18.70	23.40	15.25	18.70	23.40	23.40	27.40
Height Cylinder	A5	12.70	14.80	19.00	14.80	19.00	18.75	23.40	15.25	18.75	23.40	23.40	27.40
Length Total	B1	58.000	58.60	69.00	69.00	70.80	90.20	92.60	86.00	86.00	90.2	99.00	101.00
Length Side 1	B2	29.00	29.30	34.50	34.50	35.40	45.10	46.30	43.00	43.00	45.10	49.50	50.50
Length Side 2	B3	29.00	29.30	34.50	34.50	35.40	45.10	46.30	43.00	43.00	45.10	49.50	50.50
Flange Distance	C1	11.06	11.06	11.06	13.13	13.13	13.13	13.13	15.75	15.75	15.75	15.75	15.75
Max Bracket Width	C2	18.64	18.64	18.64	22.78	22.78	22.78	22.78	27.2	27.2	27.2	27.2	27.2
Flange Depth	D1	2.90	3.90	6.10	3.00	5.10	5.10	7.50	2.52	4.066	6.50	6.50	8.50
Body Depth	D2	6.90	6.90	6.90	8.50	8.50	8.50	8.50	10.50	10.50	10.50	10.50	10.50
Stop Extension	E TYP	0.63	1.35	1.50	1.30	1.50	1.50	2.50	1.24	2.30	2.50	3.50	4.75
Maint Clearance	F1	40.00	40.00	55.00	48.00	49.00	74.00	75.00	59.00	58.00	61.00	80.00	81.00
Maint Clearance	F2	40.00	40.00	55.00	48.00	49.00	74.00	75.00	59.00	58.00	61.00	80.00	81.00
Lifting Eye Dim X	G1	12.75	12.75	12.75	18.00	18.00	18.00	18.00	21.00	21.00	21.00	21.00	21.00
Lifting Eye Dim Y	G2	12.25	12.25	12.25	14.67	14.67	14.67	14.67	17.65	17.65	17.65	17.65	17.65
Lifting Eye Diameter	G3	1.13	1.13	1.13	0.94	0.94	0.94	0.94	1.06	1.06	1.06	1.06	1.06
P3 - P4 Distance	H	30.20	29.70		34.50	35.20			44.10	47.00	46.20		

MOUNTING PATTERN

Pattern X	J1	2.50	2.50	2.50	3.00	3.00	3.00	3.00	4.00	4.00	4.00	4.00	4.00
Pattern Y	J2	11.00	11.00	11.00	14.00	14.00	14.00	14.00	16.50	16.50	16.50	16.50	16.50
Thread Type	J3	M20-2.5	M20-2.5	M20-2.5	M24-3	M24-3	M24-3	M24-3	M30-3.5	M30-3.5	M30-3.5	M30-3.5	M30-3.5
Thread Depth		1.00	1.00	1.00	1.50	1.50	1.50	1.50	1.5	1.5	1.5	1.5	1.5

ACCESSORY PATTERN The namur slotted drive can be moved to the opposite side for field reversibility

Length	N1	5.906	5.906	5.906	7.480	7.480	7.480	7.480	9.252	9.252	9.252	9.252	9.252
Width	N2	1.181	1.181	1.181	1.181	1.181	1.181	1.181	1.181	1.181	1.181	1.181	1.181
Height	N3	1.181	1.181	1.181	1.181	1.181	1.181	1.181	1.181	1.181	1.181	1.181	1.181
Slot Width	N4	0.157	0.157	0.157	0.157	0.157	0.157	0.157	0.157	0.157	0.157	0.157	0.157
Slot Depth	N5	0.197	0.197	0.197	0.197	0.197	0.197	0.197	0.197	0.197	0.197	0.197	0.197
Thread	N6	M5-0.8	M5-0.8	M5-0.8	M5-0.8	M5-0.8	M5-0.8	M5-0.8	M5-0.8	M5-0.8	M5-0.8	M5-0.8	M5-0.8
Thread Depth		0.38	0.38	0.38	0.38	0.38	0.38	0.38	0.38	0.38	0.38	0.38	0.38

DRIVE DIMENSIONS

Shafts have two keyways 90 degrees apart. Only one keyway is required to transmit torque.
Max engagement shown with tophat. Removal of tophat allows shaft to extend through the actuator bore.

Shaft Bore	S1	3.500	3.500	3.500	4.750	4.750	4.750	4.750	6.250	6.250	6.250	6.250	6.250
Key Width	S2	0.500	0.500	0.500	1.250	1.250	1.250	1.250	1.500	1.500	1.500	1.500	1.500
Female Key Distance	S3	3.729	3.729	3.729	5.120	5.120	5.120	5.120	6.690	6.690	6.690	6.690	6.690
Key Corner Radius	S4	0.00	0.00	0.00	0.06	0.06	0.06	0.06	0.13	0.13	0.13	0.13	0.13
Shaft Depth		6.38	6.38	6.38	8.00	8.00	8.00	8.00	10.00	10.00	10.00	10.00	10.00

CENTER OF GRAVITY

COGx		0.00	0.00	0.00	0.00	0.00	0.00	0.00	0.00	0.00	0.00	0.00	0.00
COGy		0.03	0.08	0.02	0.10	0.10	0.00	0.00	0.00	0.00	0.10	0.00	0.00
COGz		0.00	0.00	0.00	0.00	0.00	0.00	0.00	0.00	0.10	0.00	0.00	0.00

Dimensions (Metric, Millimeters)

ENVELOPE DIMENSIONS		2375			2488				2575				
		DA10	DA12	SR16	DA12	DA16	SR16	SR20	DA12	DA16	DA20	SR20	SR24
Width Total	A1	514.4	566.4	673.1	614.7	723.9	723.9	843.3	679.5	767.6	888.0	889.0	990.6
Width Side 1	A2	257.2	283.2	336.6	307.3	362.0	362.0	421.6	339.7	383.8	444.0	444.5	495.3
Width Side 2	A3	257.2	283.2	336.6	307.3	362.0	362.0	421.6	339.7	383.8	444.0	444.5	495.3
Width Cylinder	A4	322.6	375.9	482.6	375.9	482.6	475.0	594.4	387.4	475.0	594.4	594.4	696.0
Height Cylinder	A5	322.6	375.9	482.6	375.9	482.6	476.3	594.4	387.4	476.3	594.4	594.4	696.0
Length Total	B1	1473.2	1488.4	1752.6	1752.6	1798.3	2291.1	2352.0	2184.4	2184.4	2291.1	2514.6	2565.4
Length Side 1	B2	736.6	744.2	876.3	876.3	899.2	1145.5	1176.0	1092.2	1092.2	1145.5	1257.3	1282.7
Length Side 2	B3	736.6	744.2	876.3	876.3	899.2	1145.5	1176.0	1092.2	1092.2	1145.5	1257.3	1282.7
Flange Distance	C1	280.9	280.9	280.9	333.4	333.4	333.4	333.4	400.1	400.1	400.1	400.1	400.1
Max Bracket Width	C2	473.5	473.5	473.5	578.6	578.6	578.6	578.6	27.2	27.2	27.2	27.2	27.2
Flange Depth	D1	73.7	99.1	154.9	76.2	129.5	129.5	190.5	64.0	103.3	165.1	165.1	215.9
Body Depth	D2	175.3	175.3	175.3	215.9	215.9	215.9	215.9	266.7	266.7	266.7	266.7	266.7
Stop Extension	E TYP	16.0	34.3	38.1	33.0	38.1	38.1	63.5	31.5	58.4	63.5	88.9	120.7
Maint Clearance	F1	1007.1	1015.7	1390.7	1213.4	1236.2	1875.8	1910.3	1488.4	1483.4	1546.1	2029.7	2061.7
Maint Clearance	F2	1007.1	1015.7	1390.7	1213.4	1236.2	1875.8	1910.3	1488.4	1483.4	1546.1	2029.7	2061.7
Lifting Eye Dim X	G1	328.9	328.9	328.9	457.2	457.2	457.2	457.2	533.4	533.4	533.4	533.4	533.4
Lifting Eye Dim Y	G2	311.1	311.1	311.1	372.6	372.6	372.6	372.6	448.3	448.3	448.3	448.3	448.3
Lifting Eye Diameter	G3	28.6	28.6	28.6	23.7	23.7	23.7	23.7	26.9	26.9	26.9	26.9	26.9
P3 - P4 Distance	H	767.1	754.4		876.3	894.1			1120.9	1193.5	1174.2		

MOUNTING PATTERN

Pattern X	J1	63.50	63.50	63.50	76.20	76.20	76.20	76.20	101.60	101.60	101.60	101.60	101.60
Pattern Y	J2	279.40	279.40	279.40	355.60	355.60	355.60	355.60	419.10	419.10	419.10	419.10	419.10
Thread Type	J3	M20-2.5	M20-2.5	M20-2.5	M24-3	M24-3	M24-3	M24-3	M30-3.5	M30-3.5	M30-3.5	M30-3.5	M30-3.5
Thread Depth		25.40	25.40	25.40	38.10	38.10	38.10	38.10	38.1	38.1	38.1	38.1	38.1

ACCESSORY PATTERN The namur slotted drive can be moved to the opposite side for field reversibility

Length	N1	150	150	150	190	190	190	190	235	235	235	235	235
Width	N2	30	30	30	30	30	30	30	30	30	30	30	30
Height	N3	30	30	30	30	30	30	30	30	30	30	30	30
Slot Width	N4	4	4	4	4	4	4	4	4	4	4	4	4
Slot Depth	N5	5	5	5	5	5	5	5	5	5	5	5	5
Thread	N6	M5-0.8	M5-0.8	M5-0.8	M5-0.8	M5-0.8	M5-0.8	M5-0.8	M5-0.8	M5-0.8	M5-0.8	M5-0.8	M5-0.8
Thread Depth		9.53	9.53	9.53	9.53	9.53	9.53	9.53	9.53	9.53	9.53	9.53	9.53

DRIVE DIMENSIONS

Shafts have two keyways 90 degrees apart. Only one keyway is required to transmit torque.
Max engagement shown with tophat. Removal of tophat allows shaft to extend through the actuator bore.

Shaft Bore	S1	88.90	88.90	88.90	120.65	120.65	120.65	120.65	158.75	158.75	158.75	158.75	158.75
Key Width	S2	12.70	12.70	12.70	31.75	31.75	31.75	31.75	38.10	38.10	38.10	38.10	38.10
Female Key Distance	S3	94.72	94.72	94.72	130.05	130.05	130.05	130.05	169.93	169.93	169.93	169.93	169.93
Key Corner Radius	S4	0.00	0.00	0.00	1.52	1.52	1.52	1.52	3.18	3.18	3.18	3.18	3.18
Shaft Depth		162	162	162	203	203	203	203	254	254	254	254	254

CENTER OF GRAVITY

COGx		0.00	0.00	0.00	0.00	0.00	0.00	0.00	0.00	0.00	0.00	0.00	0.00
COGy		0.76	2.03	0.51	2.54	2.54	0.00	0.00	0.00	0.00	2.54	0.00	0.00
COGz		0.00	0.00	0.00	0.00	0.00	0.00	0.00	0.00	2.54	0.00	0.00	0.00

Weight (Imperial, pounds)

DOUBLE ACTING (lb)

	Actuator	Stainless (FS)	Ductile (FD)
2075	DA03	17.18	14.98
	DA03	22.4	19.64
2100	DA04	30.71	27.50
	DA04	42.83	37.82
2150	DA05	52.93	46.52
	DA06	90	78

	Actuator	Stainless (FS)	Ductile (FD)
2250	DA06	136	118
	DA08	176	153
2300	DA08	230	200
	DA10	322	280
	DA12	397	345
2375	DA10	439	382
	DA12	512	445

	Actuator	Stainless (FS)	Ductile (FD)
2488	DA12	702	617
	DA16	916	789
2575	DA12	1,143	1,015
	DA16	1,329	1,161
	DA20	1,759	1,521

SPRING RETURN (lb)

	Actuator	Stainless (FS)	Ductile (FD)
2075	SR03-S42	19	15
	SR03-S62	19	15
	SR03-S72	19	15
	SR03-S82	20	16
	SR03-S92	20	16
	SR04-S42	27	22
	SR04-S47	27	22
	SR04-S52	27	22
	SR04-S55	28	23
	SR04-S62	29	24
	SR04-S67	28	23
	SR04-S71	30	24
	SR04-S72	30	25
	SR04-S75	31	25
	SR04-S79	31	26
	SR04-S82	31	25
	SR04-S85	31	26
	SR04-S89	31	26
	SR04-S92	31	26
	SR04-S94	31	26
SR04-S96	32	27	
SR04-S98	32	27	

	Actuator	Stainless (FS)	Ductile (FD)
2100	SR04-S22	32	27
	SR04-S32	33	28
	SR04-S43	33	28
	SR04-S58	33	28
	SR04-S65	33	29
	SR04-S66	34	29
	SR04-S75	35	30
	SR04-S77	36	31
	SR04-S81	36	31
	SR04-S83	36	31
	SR04-S85	36	31
	SR04-S87	36	32
	SR04-S89	36	32
	SR04-S93	37	32
	SR04-S95	37	32
	SR04-S97	37	32
	SR04-S98	37	32
	SR05-S19	44	37
	SR05-S34	44	38
	SR05-S53	46	40
SR05-S72	49	42	
SR05-S87	49	42	
SR05-S88	48	41	
SR05-S93	50	44	
SR05-S94	51	44	

	Actuator	Stainless (FS)	Ductile (FD)
2150	SR05-S22	62	53
	SR05-S34	63	54
	SR05-S53	65	56
	SR05-S65	66	57
	SR05-S72	68	60
	SR05-S85	69	60
	SR05-S87	69	60
	SR05-S94	70	61
	SR06-S19	74	63
	SR06-S32	75	64
	SR06-S47	79	68
	SR06-S72	83	72
	SR06-S75	82	71
	SR06-S82	85	73
	SR06-S91	85	74
2200	SR06-S94	87	76
	SR06-S19	102	94
	SR06-S27	105	97
	SR06-S34	106	98
	SR06-S36	107	99
	SR06-S37	107	99
	SR06-S52	111	103
	SR06-S55	111	103
	SR06-S56	113	105
	SR06-S62	114	106
SR06-S64	112	104	
SR06-S65	115	107	
SR06-S71	115	107	
SR06-S73	117	109	
SR06-S74	116	108	
SR06-S84	120	112	
SR06-S93	121	113	

	Actuator	Stainless (FS)	Ductile (FD)
2250	SR08-S03	192	178
	SR08-S31	196	182
	SR08-S02	207	193
	SR08-S21	207	193
	SR08-S01	222	208
	SR08-S11	225	211
	SR10-S03	286	220
	SR10-S02	301	235
	SR10-S01	331	265
	2300	SR12-S04	493
SR12-S03		509	425
SR12-S02		530	446
SR12-S01		560	476
2375	SR16-S05	821	730
	SR16-S04	887	796
	SR16-S03	881	790
	SR16-S02	949	858
2488	SR16-S01	1,009	918
	SR16-S03	1,254	1,057
	SR16-S02	1,397	1,200
	SR16-S01	1,623	1,426
2575	SR20-S03	1,735	1,440
	SR20-S02	1,878	1,583
	SR20-S01	2,104	1,809
	SR20-S04	2,571	2,359
	SR20-S03	2,736	2,524
	SR20-S02	2,841	2,629
	SR20-S01	3,059	2,847
	SR24-S06	3,314	2,880
SR24-S05	3,419	2,985	
SR24-S04	3,637	3,203	
SR24-S03	3,920	3,486	
SR24-S02	4,025	3,591	
SR24-S01	4,243	3,809	

Weight (Metric, Kilograms)

DOUBLE ACTING (Kg)

	Actuator	Stainless (FS)	Ductile (FD)
2075	DA03	7.79	6.79
	DA04	10.16	8.91
2100	DA03	13.93	12.47
	DA04	19.43	17.15
2150	DA04	24.01	21.10
	DA05	40.82	35.38
2200	DA06	61.69	53.52

	Actuator	Stainless (FS)	Ductile (FD)
2250	DA06	79.83	69.40
	DA08	104.33	90.72
2300	DA08	146.06	127.01
	DA10	180.08	156.49
2375	DA10	199.13	173.27
	DA12	232.24	201.85

	Actuator	Stainless (FS)	Ductile (FD)
2488	DA12	318.42	279.87
	DA16	415.49	357.88
2575	DA12	518.46	460.40
	DA16	602.82	526.62
	DA20	797.87	689.91

SPRING RETURN (Kg)

	Actuator	Stainless (FS)	Ductile (FD)
2075	SR03-S42	9	7
	SR03-S62	9	7
	SR03-S72	9	7
	SR03-S82	9	7
	SR03-S92	9	7
	SR04-S42	12	10
	SR04-S47	12	10
	SR04-S52	12	10
	SR04-S55	13	10
	SR04-S62	13	11
	SR04-S67	13	10
	SR04-S71	13	11
	SR04-S72	14	11
	SR04-S75	14	12
	SR04-S79	14	12
	SR04-S82	14	12
	SR04-S85	14	12
	SR04-S89	14	12
	SR04-S92	14	12
	SR04-S94	14	12
SR04-S96	15	12	
SR04-S98	15	12	

	Actuator	Stainless (FS)	Ductile (FD)
2100	SR04-S22	15	12
	SR04-S32	15	13
	SR04-S43	15	13
	SR04-S58	15	13
	SR04-S65	15	13
	SR04-S66	16	13
	SR04-S75	16	14
	SR04-S77	16	14
	SR04-S81	16	14
	SR04-S83	16	14
	SR04-S85	16	14
	SR04-S87	17	14
	SR04-S89	17	14
	SR04-S93	17	14
	SR04-S95	17	14
	SR04-S97	17	15
	SR04-S98	17	15
	SR05-S19	20	17
	SR05-S34	20	17
	SR05-S53	21	18
SR05-S72	22	19	
SR05-S87	22	19	
SR05-S88	22	19	
SR05-S93	23	20	
SR05-S94	23	20	

	Actuator	Stainless (FS)	Ductile (FD)
2150	SR05-S22	28	24
	SR05-S34	28	24
	SR05-S53	30	26
	SR05-S65	30	26
	SR05-S72	31	27
	SR05-S85	31	27
	SR05-S87	31	27
	SR05-S94	32	28
	SR06-S19	34	29
	SR06-S32	34	29
	SR06-S47	36	31
	SR06-S72	38	33
	SR06-S75	37	32
	SR06-S82	38	33
	SR06-S91	39	34
	SR06-S94	39	34
	SR06-S19	46	43
	SR06-S27	48	44
	SR06-S34	48	45
	SR06-S36	49	45
SR06-S37	48	45	
SR06-S52	50	47	
SR06-S55	51	47	
SR06-S56	51	48	
SR06-S62	52	48	
SR06-S64	51	47	
SR06-S65	52	48	
SR06-S71	52	49	
SR06-S73	53	49	
SR06-S74	53	49	
SR06-S84	54	51	
SR06-S93	55	51	

	Actuator	Stainless (FS)	Ductile (FD)
2250	SR08-S03	87	81
	SR08-S31	89	83
	SR08-S02	94	88
	SR08-S21	94	88
	SR08-S01	101	95
	SR08-S11	102	96
	SR10-S03	130	100
	SR10-S02	137	107
	SR10-S01	150	120
	SR12-S04	224	186
2300	SR12-S03	231	193
	SR12-S02	241	203
	SR12-S01	255	216
2375	SR16-S05	373	332
	SR16-S04	403	362
	SR16-S03	401	359
	SR16-S02	431	390
2488	SR16-S01	459	417
	SR16-S03	570	480
	SR16-S02	635	545
2575	SR16-S01	738	648
	SR20-S03	789	655
	SR20-S02	853	719
2575	SR20-S01	956	822
	SR20-S04	1,169	1,072
	SR20-S03	1,244	1,147
	SR20-S02	1,291	1,195
	SR20-S01	1,391	1,294
	SR24-S06	1,506	1,309
	SR24-S05	1,554	1,357
	SR24-S04	1,653	1,456
	SR24-S03	1,782	1,585
	SR24-S02	1,829	1,632
SR24-S01	1,929	1,732	

Performance Data

		AIR/FLUID VOLUME				PORT SIZE			STROKE TIME
		cubic inches (cuin)		liters (L)		NPT (P1, P2, P3, P4)			seconds
		BODY SIDE	ENDCAP SIDE	BODY SIDE	ENDCAP SIDE	Normal	Max	NPT(P5, P6 breather vents)	RECOMMENDED MINIMUM
2075	DA03	33	25.08	0.54	0.41	1/4"	1/4"	1/8"	0.25
	SR03		25.08		0.41	1/4"	1/4"	1/8"	0.25
	SR04		44.27		0.73	1/4"	1/4"	1/8"	0.25
2100	DA03	41	33.09	0.67	0.54	1/4"	1/4"	1/8"	0.25
	DA04	70	58.53	1.15	0.96	1/4"	1/4"	1/8"	0.25
	SR04		58.53		0.96	1/4"	1/4"	1/8"	0.25
	SR05		91.38		1.50	1/4"	1/4"	1/8"	0.25
2150	DA04	99	87.03	1.62	1.43	1/4"	1/4"	1/8"	0.25
	DA05	158	135.92	2.59	2.23	1/4"	1/4"	1/8"	0.25
	SR05		135.92		2.23	1/4"	1/4"	1/8"	0.25
	SR06		199		3.26	1/4"	1/4"	1/8"	0.25
2200	DA06	306	273	5.01	4.47	1/4"	1"	1/4"	0.25
	SR06		273		4.47	1/4"	1"	1/4"	0.25
2250	DA06	335	370	5.49	6.06	1/4"	1"	1/4"	0.25
	DA08	701	589	11.49	9.65	1/4"	1"	1/4"	0.25
	SR08		589		9.65	1/4"	1"	1/4"	0.25
	SR10		943		15.45	1/2"	1 1/2"	1/4"	0.25
2300	DA08	788	686	12.91	11.24	1/4"	1"	1/4"	0.25
	DA10	1,071	1,122	17.55	18.39	1/2"	1 1/2"	1/4"	0.25
	DA12	1,539	1,640	25.22	26.87	1"	2 1/2"	1/4"	0.25
	SR12		1,640		26.87	1"	2 1/2"	1/4"	0.25
2375	DA10	1,305	1,344	21.39	22.02	1/2"	1 1/2"	3/8"	0.5
	DA12	1,913	2,033	31.35	33.31	1"	2 1/2"	3/8"	0.5
	SR16		3,607		59.11	1 1/2"	3"	3/8"	0.5
2488	DA12	2,395	2,604	39.25	42.67	1"	2 1/2"	1/2"	0.5
	DA16	4,393	4,613	71.99	75.59	1 1/2"	3"	1/2"	0.5
	SR16		4,613		75.59	1 1/2"	3"	1/2"	0.5
	SR20		7,273		119.18	1 1/2"	3"	1/2"	0.5
2575	DA12	2,911	3,055	47.70	50.06	1"	2 1/2"	3/4"	0.5
	DA16	5,114	5,407	83.80	88.60	1 1/2"	3"	3/4"	0.5
	DA20	8,260	8,518	135.36	139.58	1 1/2"	3"	3/4"	0.5
	SR20		8,518		139.58	1 1/2"	3"	3/4"	0.5
	SR24		12,403		203.25	1 1/2"	4"	3/4"	0.5

TEMPERATURE LIMITS

LOW	STANDARD	HIGH
-60°F to 185°F	-20°F to 185°F	-20°F to 400°F
-51°C to 85°C	-28°C to 85°C	-28°C to 204°C

Environmental temperature requirements may limit the use of certain trim materials. Temperature ranges may be extended with proper insulation. Ductile iron units may be used in low temperature (less than -28°C), but stroke speed should be limited to prevent brittle fracture. Extended temperature ranges available upon request.

OUTPUT TORQUE DATA

The following tables show output torque for common pressures. For additional output information, download the interactive torque tables at QTRCO.com. Actuators may generate more torque than the maximum rating at higher pressures (refer to page 6 for torque ratings). Actuators should not be sized above their maximum torque rating unless there is no possibility that the valve will resist with a value above that rating.

AMT – Actuator Maximum Torque: The maximum possible torque output that the actuator can produce with a given springset at a given pressure (Usage: AMT@80psig, AMT@4barg, AMT@MAWP, etc). This number is often used to determine whether or not actuator torque output will exceed valve MAST.

MAVT – Max Allowable Valve Torque: The maximum torque resistance that the actuator can overcome without experiencing increased wear and early failure.

Size	2075	2100	2150	2200	2250	2300	2375	2488	2575
in-lb	2,625	5,250	10,500	14,000	28,000	56,000	112,000	280,000	700,000
N-m	296	593	1,186	1,582	3,164	6,327	12,654	31,636	79,089

MAWP – Max Allowable Working Pressure:
The maximum pressure that may be safely applied to the actuator cylinder(s).

OUTPUT TORQUE DATA (CONTINUED)

The torque values above indicate the actual actuator output torque. Some values may exceed the max rating of the actuator.

The torque values below indicate the actual actuator output torque. Some values may exceed the max rating of the actuator.

DOUBLE ACTING (in-lb)		40 psig	60 psig	80 psig	100 psig	120 psig	150 psig	Normal Operation psi	Max MAWP psi	Max Rated Torque in-lb*	
075	DA03	Start	873	1,309	1,745	2,181	2,618	120	150	2,625	
		Minimum	382	573	763	954	1,145				1,431
		End	614	921	1,229	1,536	1,843				2,304
100	DA03	Start	1,163	1,745	2,327	2,908	3,490	150	150	5,250	
		Minimum	509	763	1,018	1,272	1,527				1,909
		End	819	1,229	1,638	2,048	2,457				3,072
100	DA04	Start	2,068	3,102	4,136	5,170	6,204	101	150	5,250	
		Minimum	905	1,357	1,810	2,262	2,714				3,393
		End	1,456	2,184	2,912	3,640	4,368				5,461
150	DA04	Start	3,102	4,653	6,204	7,756	9,307	135	150	10,500	
		Minimum	1,357	2,036	2,714	3,393	4,072				5,089
		End	2,184	3,276	4,368	5,461	6,553				8,191
150	DA05	Start	4,847	7,271	9,694	12,118	14,542	86	150	10,500	
		Minimum	2,121	3,181	4,241	5,301	6,362				7,952
		End	3,413	5,119	6,826	8,532	10,239				12,798
200	DA06	Start	9,854	14,781	19,708	24,635	29,562	56	150	14,000	
		Minimum	4,072	6,107	8,143	10,179	12,215				15,268
		End	6,938	10,407	13,876	17,346	20,815				26,018
250	DA06	Start	12,318	18,477	24,635	30,794	36,953	90	150	28,000	
		Minimum	5,089	7,634	10,179	12,723	15,268				19,085
		End	8,673	13,009	17,346	21,682	26,018				32,523
250	DA08	Start	21,898	32,847	43,796	54,745	65,694	51	150	28,000	
		Minimum	9,048	13,572	18,096	22,619	27,143				33,929
		End	15,418	23,127	30,836	38,546	46,255				57,818
300	DA08	Start	26,278	39,417	52,556	65,694	78,833	85	150	56,000	
		Minimum	10,857	16,286	21,715	27,143	32,572				40,715
		End	18,502	27,753	37,004	46,255	55,506				69,382
300	DA10	Start	41,059	61,589	82,118	102,648	123,177	54	120	56,000	
		Minimum	16,965	25,447	33,929	42,412	50,894				
		End	28,909	43,364	57,818	72,273	86,728				
300	DA12	Start	59,125	88,687	118,250	147,812	177,375	37	120	56,000	
		Minimum	24,429	36,644	48,858	61,073	73,287				
		End	41,629	62,444	83,258	104,073	124,888				

OUTPUT TORQUE DATA (CONTINUED)

The torque values above indicate the actual actuator output torque. Some values may exceed the max rating of the actuator.

The torque values below indicate the actual actuator output torque. Some values may exceed the max rating of the actuator.

DOUBLE ACTING (in-lb)		40 psig	60 psig	80 psig	100 psig	120 psig	150 psig	Normal Operation psi	Max MAWP psi	Max Rated Torque in-lb*
375	DA10 Start	51,324	76,986	102,648	128,309	153,971		87	120	112,000
	Minimum	21,206	31,809	42,412	53,014	63,617				
	End	36,136	54,205	72,273	90,341	108,409				
375	DA12 Start	73,906	110,859	147,812	184,766	221,719		60	120	112,000
	Minimum	30,536	45,804	61,073	76,341	91,609				
	End	52,037	78,055	104,073	130,091	156,110				
488	DA12 Start	96,078	144,117	192,156	240,195	288,234		116	120	280,000
	Minimum	39,697	59,546	79,394	99,243	119,091				
	End	67,647	101,471	135,295	169,119	202,942				
488	DA16 Start	170,806	256,208	341,611	427,014	512,417		65	120	280,000
	Minimum	70,573	105,859	141,145	176,432	211,718				
	End	120,262	180,393	240,524	300,655	360,787				
575	DA12 Start	113,323	169,984	226,646	283,307	339,969		120	120	700,000
	Minimum	46,822	70,233	93,645	117,056	140,467				
	End	79,789	119,684	159,579	199,473	239,368				
575	DA16 Start	201,463	302,194	402,926	503,657	604,389		120	120	700,000
	Minimum	83,240	124,859	166,479	208,099	249,719				
	End	141,848	212,772	283,695	354,619	425,543				
575	DA20 Start	314,786	472,179	629,572	786,965	944,358		88	120	700,000
	Minimum	130,062	195,093	260,124	325,155	390,186				
	End	221,637	332,456	443,274	554,093	664,911				
575	DA24 Start	453,292	679,937	906,583	1,133,229	1,359,875		61	120	700,000
	Minimum	187,289	280,934	374,578	468,223	561,868				
	End	319,157	478,736	638,315	797,893	957,472				

OUTPUT TORQUE DATA (CONTINUED)

The torque values above indicate the actual actuator output torque. Some values may exceed the max rating of the actuator.

The torque values below indicate the actual actuator output torque. Some values may exceed the max rating of the actuator.

DOUBLE ACTING (N-m)		2.8 bar	4.1 bar	5.5 bar	6.9 bar	8.3 bar	12 bar	Normal Operation bar	Max MAWP bar	Max Rated Torque N.m.*	
075	DA03	Start	107	143	197	250	286	357	8.27	10.34	297
		Minimum	47	63	86	109	125	156			
		End	76	101	138	176	201	252			
100	DA03	Start	143	191	262	334	381	477	10.34	10.34	593
		Minimum	63	83	115	146	167	208			
		End	101	134	185	235	268	336			
100	DA04	Start	254	339	466	593	678	847	6.96	10.34	593
		Minimum	111	148	204	259	297	371			
		End	179	239	328	418	477	597			
150	DA04	Start	381	508	699	890	1,017	1,271	9.31	10.34	1,186
		Minimum	167	222	306	389	445	556			
		End	268	358	492	626	716	895			
150	DA05	Start	596	794	1,092	1,390	1,589	1,986	5.93	10.34	1,186
		Minimum	261	347	478	608	695	869			
		End	419	559	769	979	1,119	1,398			
200	DA06	Start	1,211	1,615	2,220	2,826	3,230	4,037	3.86	10.34	1,582
		Minimum	500	667	917	1,168	1,334	1,668			
		End	853	1,137	1,563	1,990	2,274	2,842			
250	DA06	Start	1,514	2,019	2,775	3,532	4,037	5,046	6.21	10.34	3,164
		Minimum	625	834	1,147	1,459	1,668	2,085			
		End	1,066	1,421	1,954	2,487	2,842	3,553			
250	DA08	Start	2,691	3,588	4,934	6,280	7,177	8,971	3.52	10.34	3,164
		Minimum	1,112	1,483	2,039	2,595	2,965	3,707			
		End	1,895	2,527	3,474	4,422	5,053	6,316			
300	DA08	Start	3,230	4,306	5,921	7,536	8,612	10,765	5.86	10.34	6,327
		Minimum	1,334	1,779	2,446	3,114	3,558	4,448			
		End	2,274	3,032	4,169	5,306	6,064	7,580			
300	DA10	Start	5,046	6,728	9,252	11,775	13,457		3.72	8.27	6,327
		Minimum	2,085	2,780	3,822	4,865	5,560				
		End	3,553	4,737	6,514	8,290	9,475				
300	DA12	Start	7,267	9,689	13,322	16,955	19,378		2.55	8.27	6,327
		Minimum	3,002	4,003	5,504	7,006	8,006				
		End	5,116	6,822	9,380	11,938	13,644				

OUTPUT TORQUE DATA (CONTINUED)

The torque values above indicate the actual actuator output torque. Some values may exceed the max rating of the actuator.

The torque values below indicate the actual actuator output torque. Some values may exceed the max rating of the actuator.

DOUBLE ACTING (N-m)		2.8 bar	4.1 bar	5.5 bar	6.9 bar	8.3 bar	12 bar	Normal Operation bar	Max MAWP bar	Max Rated Torque N.m.*
375	DA10	Start	6,308	8,410	11,564	14,718	16,821	6.00	8.27	12,654
		Minimum	2,606	3,475	4,778	6,081	6,950			
		End	4,441	5,922	8,142	10,363	11,843			
	DA12	Start	9,083	12,111	16,653	21,194	24,222	4.14	8.27	12,654
		Minimum	3,753	5,004	6,880	8,757	10,008			
		End	6,395	8,527	11,725	14,923	17,055			
488	DA12	Start	11,808	15,744	21,649	27,553	31,489	8.00	8.27	31,636
		Minimum	4,879	6,505	8,945	11,384	13,010			
		End	8,314	11,085	15,242	19,399	22,171			
	DA16	Start	20,992	27,990	38,486	48,982	55,980	4.48	8.27	31,636
		Minimum	8,674	11,565	15,902	20,238	23,130			
		End	14,781	19,707	27,098	34,488	39,415			
575	DA12	Start	13,928	18,570	25,534	32,498	37,141	8.27	8.27	79,089
		Minimum	5,755	7,673	10,550	13,427	15,346			
		End	9,806	13,075	17,978	22,881	26,150			
	DA16	Start	24,760	33,014	45,394	57,774	66,028	8.27	8.27	79,089
		Minimum	10,230	13,641	18,756	23,871	27,281			
		End	17,433	23,245	31,961	40,678	46,489			
DA20	Start	38,688	51,584	70,928	90,272	103,168	6.07	8.27	79,089	
	Minimum	15,985	21,313	29,306	37,298	42,627				
	End	27,240	36,320	49,940	63,560	72,640				
DA24	Start	55,711	74,281	102,137	129,992	148,562	4.21	8.27	79,089	
	Minimum	23,018	30,691	42,200	53,710	61,382				
	End	39,225	52,300	71,913	91,526	104,601				

OUTPUT TORQUE DATA (CONTINUED)

The torque values above indicate the actual actuator output torque. Some values may exceed the max rating of the actuator.

SPRING RETURN (in-lb)

Left Hand (FAIL CLOSE)		SPRINGS	40 psig	60 psig	80 psig	100 psig	120 psig	150 psig	175 psig	Normal Operation psi	Max MAWP psi	Max Rated Torque in-lb*
SR03-S42	Start	308	581	1,018	1,454	1,890	2,326	2,981	3,526	40	175	2,625
	Minimum	162	213	401	589	777	965	1,247	1,481			
	End	291	306	614	921	1,228	1,535	1,996	2,380			
SR03-S62	Start	532	427	863	1,299	1,736	2,172	2,826	3,372	60	175	2,625
	Minimum	268	105	291	478	664	850	1,130	1,363			
	End	446	83	390	697	1,004	1,311	1,772	2,156			
2075 SR03-S72	Start	619	/	720	1,156	1,592	2,029	2,683	3,228	70	175	2,625
	Minimum	327	/	236	424	612	800	1,082	1,316			
	End	589	/	302	609	916	1,224	1,684	2,068			
SR03-S82	Start	1,079	/	/	961	1,397	1,834	2,488	3,033	110	175	2,625
	Minimum	517	/	/	218	402	586	862	1,092			
	End	784	/	/	149	457	764	1,224	1,608			
SR03-S92	Start	1,210	/	/	843	1,279	1,715	2,369	2,915	130	175	2,625
	Minimum	585	/	/	152	337	521	797	1,027			
	End	902	/	/	19	326	633	1,094	1,478			

OUTPUT TORQUE DATA (CONTINUED)

The torque values above indicate the actual actuator output torque. Some values may exceed the max rating of the actuator.

SPRING RETURN (in-lb)										Normal Operation psi	Max MAWP psi	Max Rated Torque in-lb*
Left Hand (FAIL CLOSE)	SPRINGS	40 psig	60 psig	80 psig	100 psig	120 psig	150 psig	175 psig				
SR04-S42	Start	308	1,260	2,036	2,811	3,587	4,362	5,526	6,495	20	175	2,625
	Minimum	162	506	840	1,174	1,508	1,842	2,344	2,761			
	End	291	784	1,330	1,876	2,422	2,968	3,788	4,470			
SR04-S47	Start	532	1,105	1,881	2,657	3,432	4,208	5,371	6,340	40	175	2,625
	Minimum	268	396	727	1,059	1,391	1,723	2,220	2,635			
	End	446	561	1,107	1,653	2,199	2,745	3,564	4,246			
SR04-S52	Start	619	962	1,738	2,513	3,289	4,064	5,228	6,197	40	175	2,625
	Minimum	327	341	675	1,009	1,343	1,678	2,179	2,597			
	End	589	473	1,019	1,565	2,111	2,657	3,476	4,159			
SR04-S55	Start	1,079	767	1,543	2,318	3,094	3,869	5,033	6,002	70	175	2,625
	Minimum	517	137	465	792	1,119	1,446	1,936	2,345			
	End	784	13	559	1,105	1,651	2,197	3,016	3,699			
SR04-S62	Start	988	552	1,327	2,103	2,878	3,654	4,817	5,787	70	175	2,625
	Minimum	534	136	471	806	1,141	1,476	1,979	2,398			
	End	999	104	651	1,197	1,743	2,289	3,108	3,790			
SR04-S67	Start	1,210	/	1,424	2,200	2,975	3,751	4,914	5,884	70	175	2,625
	Minimum	585	/	397	724	1,051	1,379	1,869	2,278			
	End	902	/	428	974	1,520	2,066	2,885	3,568			
SR04-S71	Start	1,280	/	1,102	1,877	2,653	3,428	4,592	5,561	80	175	2,625
	Minimum	679	/	323	657	991	1,325	1,826	2,243			
	End	1,225	/	358	904	1,450	1,996	2,815	3,498			
SR04-S72	Start	1,296	/	1,036	1,812	2,587	3,363	4,526	5,496	80	175	2,625
	Minimum	697	/	307	641	976	1,310	1,812	2,230			
	End	1,291	/	343	889	1,435	1,981	2,800	3,483			
2075 SR04-S75	Start	1,519	/	882	1,657	2,433	3,208	4,372	5,341	100	175	2,625
	Minimum	803	/	198	532	866	1,200	1,700	2,118			
	End	1,445	/	119	665	1,211	1,757	2,576	3,259			
SR04-S79	Start	1,588	/	810	1,586	2,362	3,137	4,300	5,270	106	175	2,625
	Minimum	841	/	162	497	831	1,166	1,667	2,085			
	End	1,516	/	50	596	1,142	1,688	2,507	3,190			
SR04-S82	Start	1,607	/	738	1,514	2,289	3,065	4,228	5,198	108	175	2,625
	Minimum	862	/	142	477	811	1,146	1,648	2,066			
	End	1,588	/	31	577	1,123	1,669	2,488	3,171			
SR04-S85	Start	1,812	/	/	1,431	2,207	2,983	4,146	5,115	110	175	2,625
	Minimum	947	/	/	385	718	1,051	1,550	1,966			
	End	1,671	/	/	372	918	1,464	2,283	2,966			
SR04-S89	Start	2,067	/	/	1,319	2,094	2,870	4,033	5,003	113	175	2,625
	Minimum	1,052	/	/	272	604	935	1,432	1,846			
	End	1,783	/	/	117	663	1,209	2,029	2,711			
SR04-S92	Start	1,900	/	/	1,288	2,064	2,839	4,003	4,972	114	175	2,625
	Minimum	1,006	/	/	330	664	998	1,499	1,917			
	End	1,814	/	/	284	830	1,377	2,196	2,878			
SR04-S94	Start	2,198	/	/	/	1,976	2,752	3,915	4,884	116	175	2,625
	Minimum	1,120	/	/	/	537	869	1,366	1,780			
	End	1,902	/	/	/	533	1,079	1,898	2,580			
SR04-S96	Start	2,360	/	/	/	1,869	2,644	3,808	4,777	119	175	2,625
	Minimum	1,196	/	/	/	459	790	1,286	1,699			
	End	2,009	/	/	/	371	917	1,736	2,418			
SR04-S98	Start	2,490	/	/	/	1,750	2,526	3,689	4,659	122	175	2,625
	Minimum	1,263	/	/	/	391	722	1,218	1,631			
	End	2,128	/	/	/	240	786	1,605	2,288			

OUTPUT TORQUE DATA (CONTINUED)

The torque values above indicate the actual actuator output torque. Some values may exceed the max rating of the actuator.

SPRING RETURN (in-lb)										Normal Operation psi	Max MAWP psi	Max Rated Torque in-lb*
Left Hand (FAIL CLOSE)	SPRINGS	40 psig	60 psig	80 psig	100 psig	120 psig	150 psig	175 psig				
SR04-S22	Start	407	1,750	2,784	3,818	4,852	5,886	7,438	8,730	20	175	5,250
	Minimum	200	681	1,122	1,562	2,003	2,443	3,104	3,654			
	End	318	1,049	1,777	2,505	3,234	3,962	5,054	5,964			
SR04-S32	Start	701	1,622	2,656	3,690	4,725	5,759	7,310	8,602	40	175	5,250
	Minimum	321	546	980	1,413	1,847	2,281	2,931	3,473			
	End	446	755	1,483	2,211	2,939	3,667	4,759	5,670			
SR04-S43	Start	819	1,422	2,457	3,491	4,525	5,559	7,110	8,402	50	175	5,250
	Minimum	403	480	921	1,363	1,804	2,246	2,908	3,460			
	End	646	638	1,366	2,094	2,822	3,550	4,642	5,552			
SR04-S58	Start	1,420	1,382	2,416	3,450	4,484	5,518	7,070	8,362	60	175	5,250
	Minimum	595	245	664	1,084	1,504	1,924	2,554	3,079			
	End	686	36	764	1,492	2,220	2,948	4,040	4,950			
SR04-S65	Start	1,593		2,290	3,324	4,359	5,393	6,944	8,236	70	175	5,250
	Minimum	679		586	1,008	1,429	1,851	2,483	3,010			
	End	812		591	1,319	2,047	2,775	3,868	4,778			
SR04-S66	Start	1,307	929	1,963	2,997	4,031	5,065	6,616	7,909	70	175	5,250
	Minimum	668	219	663	1,107	1,551	1,995	2,660	3,215			
	End	1,139	149	877	1,605	2,334	3,062	4,154	5,064			
SR04-S75	Start	1,693		1,753	2,787	3,822	4,856	6,407	7,699	80	175	5,250
	Minimum	837		480	918	1,357	1,796	2,455	3,003			
	End	1,349		492	1,220	1,948	2,676	3,768	4,678			
SR04-S77	Start	1,714		1,645	2,679	3,713	4,747	6,298	7,591	80	175	5,250
	Minimum	868		455	896	1,337	1,778	2,440	2,991			
	End	1,457		470	1,199	1,927	2,655	3,747	4,657			
SR04-S81	Start	2,008		1,517	2,551	3,585	4,620	6,171	7,463	90	175	5,250
	Minimum	990		326	764	1,202	1,641	2,298	2,846			
	End	1,585		176	904	1,632	2,360	3,453	4,363			
SR04-S83	Start	2,099		1,435	2,469	3,503	4,538	6,089	7,381	100	175	5,250
	Minimum	1,037		279	718	1,157	1,596	2,254	2,802			
	End	1,667		85	813	1,541	2,269	3,361	4,271			
SR04-S85	Start	2,126		1,317	2,351	3,386	4,420	5,971	7,263	100	175	5,250
	Minimum	1,071		250	691	1,131	1,572	2,233	2,783			
	End	1,785		59	787	1,515	2,243	3,335	4,245			
SR04-S87	Start	2,394			2,342	3,376	4,410	5,961	7,253	100	175	5,250
	Minimum	1,159			584	1,020	1,456	2,110	2,654			
	End	1,795			519	1,247	1,975	3,067	3,977			
SR04-S89	Start	2,511			2,142	3,176	4,210	5,761	7,054	120	175	5,250
	Minimum	1,240			515	953	1,392	2,050	2,598			
	End	1,995			401	1,129	1,857	2,949	3,859			
SR04-S93	Start	2,727			2,311	3,345	4,379	5,930	7,223	120	175	5,250
	Minimum	1,271			458	890	1,322	1,970	2,510			
	End	1,825			185	913	1,641	2,733	3,643			
SR04-S95	Start	2,900			2,185	3,219	4,254	5,805	7,097	130	175	5,250
	Minimum	1,354			381	814	1,248	1,898	2,440			
	End	1,951			12	740	1,469	2,561	3,471			
SR04-S97	Start	3,113				3,136	4,170	5,721	7,013	130	175	5,250
	Minimum	1,439				717	1,149	1,795	2,334			
	End	2,035				527	1,255	2,348	3,258			
SR04-S98	Start	3,286				3,010	4,044	5,595	6,888	140	175	5,250
	Minimum	1,522				640	1,072	1,721	2,261			
	End	2,161				355	1,083	2,175	3,085			

2100

OUTPUT TORQUE DATA (CONTINUED)

The torque values above indicate the actual actuator output torque. Some values may exceed the max rating of the actuator.

SPRING RETURN (in-lb)									Normal Operation psi	Max MAWP psi	Max Rated Torque in-lb*
Left Hand (FAIL CLOSE)		SPRINGS	40 psig	60 psig	80 psig	100 psig	120 psig	150 psig			
SR05-S19	Start	580	2,767	4,382	5,998	7,614	9,230	11,653	20	150	5,250
	Minimum	287	1,094	1,784	2,474	3,165	3,855	4,891			
	End	465	1,696	2,833	3,971	5,109	6,246	7,953			
SR05-S34	Start	1,199	2,261	3,877	5,493	7,109	8,724	11,148	40	150	5,250
	Minimum	596	776	1,463	2,149	2,836	3,522	4,552			
	End	970	1,076	2,214	3,351	4,489	5,626	7,333			
SR05-S53	Start	1,796	1,596	3,212	4,828	6,444	8,059	10,483	60	150	5,250
	Minimum	934	452	1,145	1,838	2,531	3,224	4,264			
	End	1,635	479	1,617	2,754	3,892	5,030	6,736			
SR05-S72	Start	2,376		2,747	4,363	5,979	7,594	10,018	70	150	5,250
	Minimum	1,221		854	1,545	2,237	2,929	3,966			
	End	2,100		1,037	2,175	3,312	4,450	6,157			
SR05-S87	Start	2,995		2,242	3,858	5,473	7,089	9,513	90	150	5,250
	Minimum	1,530		541	1,232	1,922	2,613	3,648			
	End	2,605		417	1,555	2,693	3,830	5,537			
SR05-S88	Start	3,484			4,638	6,254	7,870	10,294	87	150	5,250
	Minimum	1,496			1,130	1,787	2,444	3,429			
	End	1,825			1,067	2,205	3,342	5,049			
SR05-S93	Start	4,063			4,174	5,789	7,405	9,829	93	150	5,250
	Minimum	1,786			863	1,525	2,187	3,180			
	End	2,289			487	1,625	2,763	4,469			
SR05-S94	Start	4,683				5,284	6,900	9,324	99	150	5,250
	Minimum	2,097				1,236	1,903	2,903			
	End	2,795				1,005	2,143	3,849			

2100

OUTPUT TORQUE DATA (CONTINUED)

The torque values above indicate the actual actuator output torque. Some values may exceed the max rating of the actuator.

		SPRING RETURN (in-lb)							Normal Operation psi	Max MAWP psi	Max Rated Torque in-lb*
Left Hand (FAIL CLOSE)		SPRINGS	40 psig	60 psig	80 psig	100 psig	120 psig	150 psig			
SR05-S22	Start	1,096	4,137	6,561	8,985	11,408	13,832	17,467	30	150	10,500
	Minimum	505	1,534	2,553	3,573	4,592	5,611	7,141			
	End	710	2,317	4,024	5,730	7,437	9,143	11,703			
SR05-S34	Start	1,838	3,479	5,903	8,326	10,750	13,173	16,809	40	150	10,500
	Minimum	888	1,159	2,182	3,205	4,228	5,251	6,786			
	End	1,368	1,575	3,281	4,987	6,694	8,400	10,960			
SR05-S53	Start	2,677	2,493	4,917	7,340	9,764	12,188	15,823	60	150	10,500
	Minimum	1,373	702	1,739	2,776	3,814	4,851	6,407			
	End	2,354	736	2,443	4,149	5,856	7,562	10,122			
SR05-S65	Start	3,573		4,738	7,162	9,586	12,009	15,645	70	150	10,500
	Minimum	1,697		1,360	2,379	3,398	4,417	5,945			
	End	2,532		1,546	3,253	4,959	6,666	9,225			
SR05-S72	Start	3,772		4,207	6,631	9,054	11,478	15,113	80	150	10,500
	Minimum	1,878		1,213	2,243	3,273	4,304	5,849			
	End	3,064		1,347	3,053	4,760	6,466	9,026			
SR05-S85	Start	4,669		4,029	6,452	8,876	11,299	14,935	90	150	10,500
	Minimum	2,202		850	1,868	2,885	3,903	5,429			
	End	3,242		451	2,157	3,863	5,570	8,130			
SR05-S87	Start	4,515		3,548	5,972	8,396	10,819	14,455	90	150	10,500
	Minimum	2,260		835	1,867	2,898	3,930	5,478			
	End	3,723		604	2,311	4,017	5,724	8,283			
SR05-S94	Start	5,411			5,794	8,217	10,641	14,276	100	150	10,500
	Minimum	2,584			1,498	2,518	3,539	5,069			
	End	3,901			1,414	3,121	4,827	7,387			
SR06-S19	Start	1,434	5,883	9,373	12,863	16,353	19,843	25,078	20	150	10,500
	Minimum	699	2,257	3,735	5,213	6,692	8,170	10,387			
	End	1,097	3,481	5,938	8,395	10,852	13,310	16,996			
SR06-S32	Start	2,484	5,080	8,570	12,060	15,550	19,040	24,275	40	150	10,500
	Minimum	1,211	1,741	3,217	4,693	6,169	7,645	9,859			
	End	1,900	2,430	4,887	7,345	9,802	12,259	15,945			
SR06-S47	Start	3,404	3,755	7,245	10,735	14,225	17,715	22,950	50	150	10,500
	Minimum	1,798	1,206	2,707	4,209	5,710	7,212	9,464			
	End	3,226	1,510	3,968	6,425	8,882	11,339	15,025			
SR06-S72	Start	4,838	2,658	6,148	9,638	13,128	16,618	21,853	70	150	10,500
	Minimum	2,497	495	1,991	3,486	4,982	6,478	8,721			
	End	4,322	76	2,534	4,991	7,448	9,905	13,591			
SR06-S75	Start	6,235		6,704	10,194	13,684	17,174	22,409	80	150	10,500
	Minimum	2,804		1,519	2,961	4,402	5,843	8,004			
	End	3,766		1,137	3,594	6,052	8,509	12,195			
SR06-S82	Start	5,889		5,344	8,834	12,324	15,814	21,049	80	150	10,500
	Minimum	3,009		1,467	2,959	4,451	5,943	8,181			
	End	5,126		1,483	3,940	6,398	8,855	12,541			
SR06-S91	Start	7,669			9,097	12,587	16,077	21,312	88	150	10,500
	Minimum	3,507			2,294	3,744	5,194	7,369			
	End	4,863			2,160	4,618	7,075	10,761			
SR06-S94	Start	8,719			8,294	11,784	15,274	20,509	92	150	10,500
	Minimum	4,022			1,792	3,246	4,699	6,879			
	End	5,666			1,110	3,567	6,024	9,710			

OUTPUT TORQUE DATA (CONTINUED)

The torque values above indicate the actual actuator output torque. Some values may exceed the max rating of the actuator.

SPRING RETURN (in-lb)									Normal Operation psi	Max MAWP psi	Max Rated Torque in-lb*
Left Hand (FAIL CLOSE)	SPRINGS	40 psig	60 psig	80 psig	100 psig	120 psig	150 psig				
SR06-S19	Start	1,861	7,852	12,505	17,159	21,812	26,465	33,445	20	150	14,000
	Minimum	914	3,038	5,014	6,990	8,966	10,942	13,906			
	End	1,455	4,692	7,968	11,244	14,521	17,797	22,712			
SR06-S27	Start	2,739	7,010	11,663	16,317	20,970	25,623	32,603	30	150	14,000
	Minimum	1,380	2,583	4,565	6,547	8,528	10,510	13,482			
	End	2,297	3,814	7,091	10,367	13,643	16,920	21,834			
SR06-S34	Start	3,566	6,803	11,456	16,109	20,763	25,416	32,396	40	150	14,000
	Minimum	1,688	2,224	4,180	6,137	8,093	10,049	12,983			
	End	2,504	2,987	6,263	9,540	12,816	16,093	21,007			
SR06-S36	Start	3,861	6,684	11,337	15,991	20,644	25,297	32,277	40	150	14,000
	Minimum	1,808	2,087	4,034	5,981	7,929	9,876	12,797			
	End	2,623	2,691	5,968	9,244	12,521	15,797	20,711			
SR06-S37	Start	3,747	6,164	10,817	15,471	20,124	24,777	31,757	40	150	14,000
	Minimum	1,888	2,075	4,057	6,039	8,021	10,003	12,975			
	End	3,143	2,805	6,082	9,358	12,634	15,911	20,825			
SR06-S52	Start	5,427	5,348	10,001	14,654	19,308	23,961	30,941	60	150	14,000
	Minimum	2,602	1,321	3,282	5,243	7,205	9,166	12,108			
	End	3,959	1,126	4,402	7,679	10,955	14,231	19,146			
SR06-S55	Start	5,722	5,229	9,882	14,536	19,189	23,843	30,823	60	150	14,000
	Minimum	2,722	1,196	3,155	5,114	7,072	9,031	11,970			
	End	4,078	830	4,107	7,383	10,659	13,936	18,850			
SR06-S56	Start	5,572	4,597	9,250	13,903	18,557	23,210	30,190	60	150	14,000
	Minimum	2,815	1,153	3,138	5,122	7,106	9,091	12,067			
	End	4,710	981	4,257	7,534	10,810	14,087	19,001			
SR06-S62	Start	6,304	4,506	9,159	13,813	18,466	23,119	30,099	60	150	14,000
	Minimum	3,068	864	2,830	4,796	6,761	8,727	11,676			
	End	4,801	248	3,525	6,801	10,078	13,354	18,268			
SR06-S64	Start	7,411		10,461	15,114	19,768	24,421	31,401	70	150	14,000
	Minimum	3,083		2,521	4,389	6,256	8,124	10,926			
	End	3,499		2,418	5,694	8,971	12,247	17,162			
SR06-S65	Start	6,600		9,041	13,694	18,347	23,001	29,981	70	150	14,000
	Minimum	3,188		2,712	4,679	6,646	8,613	11,563			
	End	4,919		3,229	6,506	9,782	13,058	17,973			
SR06-S71	Start	7,313		8,313	12,966	17,620	22,273	29,253	70	150	14,000
	Minimum	3,576		2,328	4,297	6,265	8,233	11,185			
	End	5,647		2,516	5,792	9,069	12,345	17,260			
SR06-S73	Start	7,433		7,795	12,448	17,102	21,755	28,735	80	150	14,000
	Minimum	3,729		2,210	4,190	6,170	8,149	11,119			
	End	6,165		2,396	5,673	8,949	12,226	17,140			
SR06-S74	Start	7,609		8,195	12,848	17,501	22,155	29,135	80	150	14,000
	Minimum	3,696		2,206	4,174	6,141	8,109	11,060			
	End	5,766		2,220	5,497	8,773	12,049	16,964			
SR06-S84	Start	8,310		6,953	11,606	16,260	20,913	27,893	90	150	14,000
	Minimum	4,195		1,758	3,743	5,727	7,712	10,688			
	End	7,007		1,519	4,795	8,072	11,348	16,263			
SR06-S93	Start	9,319		6,107	10,760	15,414	20,067	27,047	93	150	14,000
	Minimum	4,704		1,246	3,230	5,213	7,196	10,171			
	End	7,853		510	3,786	7,063	10,339	15,254			

2200

OUTPUT TORQUE DATA (CONTINUED)

The torque values above indicate the actual actuator output torque. Some values may exceed the max rating of the actuator.

SPRING RETURN (in-lb)									Normal Operation psi	Max MAWP psi	Max Rated Torque in-lb*
Left Hand (FAIL CLOSE)	SPRINGS	40 psig	60 psig	80 psig	100 psig	120 psig	150 psig				
SR08-S03	Start	4,915	17,012	27,961	38,910	49,859	60,808	77,232	30	150	28,000
	Minimum	2,509	6,472	10,962	15,452	19,942	24,433	31,168			
	End	4,886	10,503	18,212	25,921	33,630	41,339	52,903			
SR08-S31	Start	7,616	14,488	25,438	36,387	47,336	58,285	74,708	40	150	28,000
	Minimum	3,856	5,117	9,604	14,090	18,577	23,063	29,793			
	End	7,410	7,802	15,511	23,220	30,929	38,639	50,202			
SR08-S02	Start	11,085	11,023	21,972	32,921	43,870	54,819	71,243	50	150	28,000
	Minimum	5,630	3,347	7,836	12,325	16,813	21,302	28,035			
	End	10,875	4,333	12,042	19,752	27,461	35,170	46,733			
SR08-S21	Start	11,430	10,536	21,486	32,435	43,384	54,333	70,756	60	150	28,000
	Minimum	5,833	3,149	7,641	12,132	16,623	21,115	27,852			
	End	11,362	3,989	11,698	19,407	27,116	34,825	46,389			
SR08-S01	Start	16,000		17,086	28,035	38,984	49,933	66,357	79	150	28,000
	Minimum	8,138		5,329	9,818	14,307	18,796	25,530			
	End	15,761		7,127	14,836	22,545	30,254	41,818			
SR08-S11	Start	19,046		14,076	25,025	35,974	46,923	63,347	85	150	28,000
	Minimum	9,689		3,777	8,265	12,754	17,242	23,975			
	End	18,771		4,082	11,791	19,500	27,209	38,773			
SR10-S03	Start	11,085	23,341	40,449	57,557	74,665	91,773		40	120	28,000
	Minimum	5,630	8,397	15,411	22,424	29,438	36,451				
	End	10,875	13,006	25,052	37,097	49,143	61,188				
SR10-S02	Start	16,000	18,455	35,563	52,670	69,778	86,886		60	120	28,000
	Minimum	8,138	5,890	12,904	19,918	26,932	33,946				
	End	15,761	8,091	20,136	32,182	44,227	56,273				
SR10-S01	Start	23,363	11,136	28,244	45,352	62,460	79,567		59	120	28,000
	Minimum	11,896	2,133	9,148	16,162	23,177	30,191				
	End	23,080	728	12,773	24,819	36,864	48,910				

OUTPUT TORQUE DATA (CONTINUED)

The torque values above indicate the actual actuator output torque. Some values may exceed the max rating of the actuator.

SPRING RETURN (in-lb)								Normal Operation psi	Max MAWP psi	Max Rated Torque in-lb*
Left Hand (FAIL CLOSE)	SPRINGS	40 psig	60 psig	80 psig	100 psig	120 psig				
SR12-S04	Start	25,900	35,293	64,856	94,418	123,981	153,543	50	120	56,000
	Minimum	12,855	11,319	23,406	35,492	47,579	59,666			
	End	23,832	15,729	36,544	57,358	78,173	98,988			
SR12-S03	Start	29,503	31,978	61,540	91,103	120,665	150,228	50	120	56,000
	Minimum	14,643	9,532	21,620	33,707	45,794	57,882			
	End	27,147	12,126	32,941	53,755	74,570	95,384			
SR12-S02	Start	37,246	24,853	54,416	83,978	113,541	143,103	60	120	56,000
	Minimum	18,486	5,685	17,770	29,856	41,941	54,026			
	End	34,272	4,383	25,198	46,013	66,827	87,642			
SR12-S01	Start	46,325		46,062	75,625	105,187	134,750	66	120	56,000
	Minimum	22,991		13,268	25,354	37,440	49,527			
	End	42,625		16,119	36,934	57,748	78,563			
SR16-S05	Start	34,383	94,749	160,443	226,137	291,832	357,526	30	120	112,000
	Minimum	18,015	36,039	63,067	90,094	117,121	144,148			
	End	36,640	58,127	104,381	150,636	196,891	243,145			
SR16-S04	Start	47,014	81,287	146,982	212,676	278,371	344,065	40	120	112,000
	Minimum	24,633	29,422	56,450	83,478	110,506	137,534			
	End	50,102	45,495	91,750	138,004	184,259	230,514			
SR16-S03	Start	52,628	75,305	140,999	206,694	272,388	338,083	50	120	112,000
	Minimum	27,575	26,474	53,499	80,523	107,548	134,573			
	End	56,084	39,881	86,136	132,391	178,645	224,900			
SR16-S02	Start	63,151	64,091	129,785	195,480	261,174	326,868	50	120	112,000
	Minimum	33,088	20,958	47,981	75,005	102,028	129,051			
	End	67,298	29,358	75,613	121,867	168,122	214,377			
SR16-S01	Start	81,397	44,647	110,341	176,036	241,730	307,425	60	120	112,000
	Minimum	42,648	11,386	38,403	65,420	92,437	119,454			
	End	86,742	11,112	57,367	103,622	149,877	196,131			

OUTPUT TORQUE DATA (CONTINUED)

The torque values above indicate the actual actuator output torque. Some values may exceed the max rating of the actuator.

SPRING RETURN (in-lb)								Normal Operation psi	Max MAWP psi	Max Rated Torque in-lb*
Left Hand (FAIL CLOSE)	SPRINGS	40 psig	60 psig	80 psig	100 psig	120 psig				
SR16-S03	Start	75,223	98,588	183,990	269,393	354,796	440,199	50	120	280,000
	Minimum	37,904	32,053	67,032	102,011	136,990	171,969			
	End	72,218	45,039	105,170	165,301	225,432	285,563			
2488 SR16-S02	Start	101,571	67,292	152,695	238,097	323,500	408,903	60	120	280,000
	Minimum	52,321	17,818	52,887	87,957	123,026	158,095			
	End	103,514	18,692	78,823	138,954	199,085	259,216			
SR16-S01	Start	176,794		80,477	165,880	251,282	336,685	106	120	280,000
	Minimum	90,225		14,838	49,860	84,881	119,902			
	End	175,731		3,599	63,731	123,862	183,993			
SR20-S03	Start	75,223	194,666	328,108	461,550	594,991	728,433	30	120	280,000
	Minimum	37,904	71,435	126,105	180,775	235,445	290,115			
	End	72,218	112,686	206,641	300,596	394,551	488,506			
2488 SR20-S02	Start	101,571	163,370	296,812	430,254	563,696	697,137	40	120	280,000
	Minimum	52,321	57,255	112,043	166,830	221,618	276,406			
	End	103,514	86,339	180,294	274,249	368,204	462,158			
SR20-S01	Start	176,794	91,152	224,594	358,036	491,478	624,920	68	120	280,000
	Minimum	90,225	19,225	73,950	128,676	183,401	238,126			
	End	175,731	11,116	105,071	199,025	292,980	386,935			

OUTPUT TORQUE DATA (CONTINUED)

The torque values above indicate the actual actuator output torque. Some values may exceed the max rating of the actuator.

SPRING RETURN (in-lb)								Normal Operation psi	Max MAWP psi	Max Rated Torque in-lb*
Left Hand (FAIL CLOSE)		SPRINGS	40 psig	60 psig	80 psig	100 psig	120 psig			
SR20-S04	Start	194,540	134,337	291,730	449,123	606,516	763,909	60	120	700,000
	Minimum	96,827	31,939	96,321	160,704	225,086	289,469			
	End	180,449	27,097	137,916	248,734	359,553	470,371			
SR20-S03	Start	246,715	/	246,007	403,400	560,792	718,185	80	120	700,000
	Minimum	122,288	/	70,733	135,074	199,414	263,754			
	End	226,172	/	85,741	196,559	307,378	418,196			
SR20-S02	Start	270,815	/	216,551	373,944	531,337	688,730	90	120	700,000
	Minimum	135,632	/	57,609	122,023	186,436	250,850			
	End	255,628	/	61,640	172,459	283,277	394,096			
SR20-S01	Start	356,035	/	/	298,447	455,840	613,233	110	120	700,000
	Minimum	177,373	/	/	80,146	144,526	208,906			
	End	331,124	/	/	87,239	198,058	308,876			
SR24-S06	Start	246,715	227,119	453,765	680,411	907,057	1,133,703	60	120	700,000
	Minimum	122,288	63,007	155,654	248,302	340,949	433,596			
	End	226,172	72,442	232,021	391,600	551,178	710,757			
SR24-S05	Start	270,815	197,664	424,310	650,955	877,601	1,104,247	60	120	700,000
	Minimum	135,632	49,899	142,665	235,431	328,196	420,962			
	End	255,628	48,342	207,921	367,499	527,078	686,657			
SR24-S04	Start	356,035	/	348,813	575,459	802,105	1,028,751	80	120	700,000
	Minimum	177,373	/	100,768	193,482	286,195	378,909			
	End	331,124	/	122,701	282,280	441,858	601,437			
SR24-S03	Start	414,389	/	283,388	510,034	736,679	963,325	90	120	700,000
	Minimum	208,564	/	69,877	162,691	255,505	348,318			
	End	396,550	/	64,347	223,925	383,504	543,083			
SR24-S02	Start	438,489	/	253,932	480,578	707,224	933,869	99	120	700,000
	Minimum	221,908	/	56,718	149,594	242,469	335,345			
	End	426,005	/	40,247	199,825	359,404	518,982			
SR24-S01	Start	523,709	/	/	405,081	631,727	858,373	106	120	700,000
	Minimum	263,649	/	/	107,588	200,397	293,206			
	End	501,502	/	/	114,606	274,184	433,763			

OUTPUT TORQUE DATA (CONTINUED)

The torque values above indicate the actual actuator output torque. Some values may exceed the max rating of the actuator.

SPRING RETURN (N-m)										Normal Operation bar	Max MAWP bar	Max Rated Torque N-m*
Left Hand (FAIL CLOSE)	SPRINGS	3 bar	4 bar	5.5 bar	7 bar	8 bar	10 bar	12 bar				
SR03-S42	Start	35	74	110	164	217	253	325	396	2.76	12.07	297
	Minimum	18	28	43	66	89	105	136	166			
	End	33	41	66	104	141	167	217	267			
SR03-S62	Start	60	57	93	146	200	236	307	379	4.14	12.07	297
	Minimum	30	16	31	54	77	92	122	153			
	End	50	15	41	78	116	141	192	242			
2075 SR03-S72	Start	70	41	76	130	184	219	291	362	4.83	12.07	297
	Minimum	37	9	25	48	71	86	117	148			
	End	67	6	31	68	106	131	182	232			
SR03-S82	Start	122			108	162	197	269	340	7.58	12.07	297
	Minimum	58			24	47	62	92	122			
	End	89			16	54	79	130	180			
SR03-S92	Start	137			95	148	184	255	327	8.96	12.07	297
	Minimum	66			17	40	55	85	115			
	End	102			2	39	65	115	165			

OUTPUT TORQUE DATA (CONTINUED)

The torque values above indicate the actual actuator output torque. Some values may exceed the max rating of the actuator.

		Left Hand (FAIL CLOSE)	SPRINGS	3 bar	4 bar	5.5 bar	7 bar	8 bar	10 bar	12 bar	Normal Operation bar	Max MAWP bar	Max Rated Torque N-m*
SR04-S42	Start		35	158	221	317	412	475	603	730	1.38	12.07	297
	Minimum		18	64	91	132	173	201	255	310			
	End		33	99	144	211	278	323	413	502			
SR04-S47	Start		60	140	204	299	394	458	585	712	2.76	12.07	297
	Minimum		30	51	78	119	160	187	242	296			
	End		50	74	119	186	253	298	387	477			
SR04-S52	Start		70	124	188	283	378	442	569	696	2.76	12.07	297
	Minimum		37	45	73	114	155	182	237	292			
	End		67	64	109	176	243	288	377	467			
SR04-S55	Start		122	102	166	261	356	420	547	674	4.83	12.07	297
	Minimum		58	22	49	89	129	156	210	263			
	End		89	12	57	124	191	236	325	415			
SR04-S62	Start		112	78	141	237	332	395	523	650	4.83	12.07	297
	Minimum		60	22	49	91	132	159	214	269			
	End		113	23	67	134	202	246	336	425			
SR04-S67	Start		137		152	248	343	406	533	661	4.83	12.07	297
	Minimum		66		41	81	122	148	202	256			
	End		102		42	109	176	221	311	400			
SR04-S71	Start		145		116	211	306	370	497	624	5.52	12.07	297
	Minimum		77		33	74	115	142	197	252			
	End		138		34	101	169	213	303	392			
SR04-S72	Start		146		108	204	299	363	490	617	5.52	12.07	297
	Minimum		79		31	72	113	141	195	250			
	End		146		33	100	167	212	301	391			
2075 SR04-S75	Start		172		91	186	282	345	472	599	6.89	12.07	297
	Minimum		91		19	60	101	128	183	237			
	End		163		7	74	142	186	276	365			
SR04-S79	Start		179			178	274	337	464	591	7.31	12.07	297
	Minimum		95			56	97	124	179	234			
	End		171			67	134	178	268	357			
SR04-S82	Start		182			170	265	329	456	583	7.45	12.07	297
	Minimum		97			53	95	122	177	232			
	End		179			65	132	176	266	355			
SR04-S85	Start		205			161	256	320	447	574	7.58	12.07	297
	Minimum		107			43	84	111	166	220			
	End		189			41	108	153	243	332			
SR04-S89	Start		234			148	243	307	434	561	7.79	12.07	297
	Minimum		119			30	71	98	152	207			
	End		201			13	80	124	214	303			
SR04-S92	Start		215			145	240	303	430	558	7.86	12.07	297
	Minimum		114			37	78	105	160	215			
	End		205			31	99	143	233	322			
SR04-S94	Start		248				230	293	421	548	8.00	12.07	297
	Minimum		127				64	91	145	199			
	End		215				65	110	199	289			
SR04-S96	Start		267				218	281	408	536	8.20	12.07	297
	Minimum		135				55	82	136	190			
	End		227				47	91	181	270			
SR04-S98	Start		281				204	268	395	522	8.41	12.07	297
	Minimum		143				47	74	128	183			
	End		240				32	77	166	256			

OUTPUT TORQUE DATA (CONTINUED)

The torque values above indicate the actual actuator output torque. Some values may exceed the max rating of the actuator.

SPRING RETURN (N-m)

Left Hand (FAIL CLOSE)		SPRINGS	3 bar	4 bar	5.5 bar	7 bar	8 bar	10 bar	12 bar	Normal Operation bar	Max MAWP bar	Max Rated Torque N-m*
SR04-S22	Start	46	218	303	430	557	642	811	981	1.38	12.07	593
	Minimum	23	86	122	176	230	266	338	411			
	End	36	133	193	282	372	431	551	670			
SR04-S32	Start	79	204	289	416	543	627	797	966	2.76	12.07	593
	Minimum	36	70	106	159	212	248	319	390			
	End	50	100	159	249	338	398	517	637			
SR04-S43	Start	92	181	266	393	520	605	774	944	3.45	12.07	593
	Minimum	46	63	99	153	208	244	316	389			
	End	73	86	146	236	325	385	504	623			
SR04-S58	Start	160	177	261	388	516	600	770	939	4.14	12.07	593
	Minimum	67	36	70	122	174	208	277	346			
	End	78	18	78	168	257	317	436	555			
SR04-S65	Start	180	/	247	374	501	586	756	925	4.83	12.07	593
	Minimum	77	/	61	113	165	200	269	338			
	End	92	/	59	148	238	297	417	536			
SR04-S66	Start	148	125	210	337	464	549	719	888	4.83	12.07	593
	Minimum	75	34	70	124	179	215	288	361			
	End	129	31	91	180	270	330	449	568			
SR04-S75	Start	191	/	187	314	441	525	695	864	5.52	12.07	593
	Minimum	95	/	49	103	157	193	265	337			
	End	152	/	47	137	226	286	405	525			
SR04-S77	Start	194	/	174	301	428	513	683	852	5.52	12.07	593
	Minimum	98	/	46	101	155	191	263	336			
	End	165	/	45	134	224	284	403	522			
SR04-S81	Start	227	/	160	287	414	499	668	838	6.21	12.07	593
	Minimum	112	/	32	86	140	176	247	319			
	End	179	/	12	101	191	250	370	489			
SR04-S83	Start	237	/	151	278	405	489	659	828	6.89	12.07	593
	Minimum	117	/	27	81	135	170	242	314			
	End	188	/	1	91	180	240	359	479			
SR04-S85	Start	240	/	264	391	476	646	815	985	6.89	12.07	593
	Minimum	121	/	77	132	168	240	312	384			
	End	202	/	88	177	237	356	476	596			
SR04-S87	Start	270	/	263	390	475	645	814	984	6.89	12.07	593
	Minimum	131	/	65	119	155	226	298	370			
	End	203	/	58	147	207	326	445	564			
SR04-S89	Start	284	/	241	368	452	622	791	960	8.27	12.07	593
	Minimum	140	/	58	111	147	219	291	363			
	End	225	/	44	134	194	313	432	551			
SR04-S93	Start	308	/	260	387	472	641	811	981	8.27	12.07	593
	Minimum	144	/	51	104	140	210	281	352			
	End	206	/	20	109	169	288	408	528			
SR04-S95	Start	328	/	246	373	457	627	796	966	8.96	12.07	593
	Minimum	153	/	42	96	131	202	273	344			
	End	220	/	0	90	150	269	388	508			
SR04-S97	Start	352	/	363	448	617	787	957	1127	8.96	12.07	593
	Minimum	163	/	85	120	191	261	332	403			
	End	230	/	66	126	245	364	483	603			
SR04-S98	Start	371	/	349	434	603	773	943	1113	9.65	12.07	593
	Minimum	172	/	76	111	182	253	324	395			
	End	244	/	46	106	225	345	465	585			

2100

OUTPUT TORQUE DATA (CONTINUED)

The torque values above indicate the actual actuator output torque. Some values may exceed the max rating of the actuator.

SPRING RETURN (N-m)									Normal Operation bar	Max MAWP bar	Max Rated Torque N-m*
Left Hand (FAIL CLOSE)		SPRINGS	3 bar	4 bar	5.5 bar	7 bar	8 bar	10 bar			
SR05-S19	Start	65	345	477	676	874	1,007	1,271	1.38	10.34	593
	Minimum	32	137	194	279	364	420	533			
	End	53	214	307	447	587	680	867			
SR05-S34	Start	136	288	420	619	817	949	1,214	2.76	10.34	593
	Minimum	67	101	158	242	326	383	495			
	End	110	144	237	377	517	610	797			
SR05-S53	Start	203	212	345	543	742	874	1,139	4.14	10.34	593
	Minimum	105	65	122	207	292	349	462			
	End	185	77	170	310	450	543	729			
SR05-S72	Start	268	160	292	491	689	822	1,087	4.83	10.34	593
	Minimum	138	32	89	174	259	315	429			
	End	237	11	104	244	384	477	664			
SR05-S87	Start	338		235	434	632	765	1,030	6.21	10.34	593
	Minimum	173		53	138	223	280	393			
	End	294		34	174	314	407	594			
SR05-S88	Start	394			522	721	853	1,118	6.00	10.34	593
	Minimum	169			127	208	261	369			
	End	206			119	259	352	539			
SR05-S93	Start	459			469	668	800	1,065	6.41	10.34	593
	Minimum	202			97	178	232	341			
	End	259			54	193	287	473			
SR05-S94	Start	529				611	743	1,008	6.83	10.34	593
	Minimum	237				145	200	309			
	End	316				123	217	403			

2100

OUTPUT TORQUE DATA (CONTINUED)

The torque values above indicate the actual actuator output torque. Some values may exceed the max rating of the actuator.

		SPRING RETURN (N-m)							Normal Operation bar	Max MAWP bar	Max Rated Torque N-m*
Left Hand (FAIL CLOSE)		SPRINGS	3 bar	4 bar	5.5 bar	7 bar	8 bar	10 bar			
SR05-S22	Start	124	516	714	1,012	1,310	1,508	1,906	2.07	10.34	1,186
	Minimum	57	194	277	402	528	611	778			
	End	80	296	435	645	855	995	1,274			
SR05-S34	Start	208	441	640	938	1,235	1,434	1,831	2.76	10.34	1,186
	Minimum	100	151	235	361	487	570	738			
	End	155	212	352	561	771	911	1,190			
SR05-S53	Start	302	330	528	826	1,124	1,323	1,720	4.14	10.34	1,186
	Minimum	155	100	185	312	440	525	695			
	End	266	117	257	467	676	816	1,096			
SR05-S65	Start	404	310	508	806	1,104	1,303	1,700	4.83	10.34	1,186
	Minimum	192	59	142	267	393	476	643			
	End	286	16	156	365	575	715	994			
SR05-S72	Start	426		448	746	1,044	1,242	1,640	5.52	10.34	1,186
	Minimum	212		125	252	379	463	632			
	End	346		133	343	553	692	972			
SR05-S85	Start	527		428	726	1,024	1,222	1,619	6.21	10.34	1,186
	Minimum	249		85	210	335	418	585			
	End	366		32	242	451	591	871			
SR05-S87	Start	510		374	672	969	1,168	1,565	6.21	10.34	1,186
	Minimum	255		83	210	336	421	590			
	End	421		49	259	469	608	888			
SR05-S94	Start	611			651	949	1,148	1,545	6.89	10.34	1,186
	Minimum	292			168	293	377	544			
	End	441			158	367	507	787			
SR06-S19	Start	162	734	1,020	1,449	1,878	2,164	2,736	1.38	10.34	1,186
	Minimum	79	284	405	587	769	890	1,132			
	End	124	442	643	945	1,247	1,449	1,851			
SR06-S32	Start	281	643	929	1,358	1,787	2,073	2,645	2.76	10.34	1,186
	Minimum	137	226	347	528	710	831	1,073			
	End	215	323	525	827	1,129	1,330	1,733			
SR06-S47	Start	385	493	779	1,208	1,637	1,923	2,495	3.45	10.34	1,186
	Minimum	203	166	289	474	658	781	1,027			
	End	364	219	421	723	1,025	1,226	1,629			
SR06-S72	Start	547	370	655	1,084	1,513	1,799	2,371	4.83	10.34	1,186
	Minimum	282	86	208	392	576	698	943			
	End	488	57	259	561	863	1,064	1,467			
SR06-S75	Start	704		718	1,147	1,576	1,862	2,434	5.52	10.34	1,186
	Minimum	317		156	333	510	628	864			
	End	426		101	403	705	906	1,309			
SR06-S82	Start	665		565	994	1,423	1,709	2,280	5.52	10.34	1,186
	Minimum	340		149	332	516	638	883			
	End	579		140	442	744	945	1,348			
SR06-S91	Start	866			1,023	1,452	1,738	2,310	6.07	10.34	1,186
	Minimum	396			257	435	554	792			
	End	549			241	543	744	1,147			
SR06-S94	Start	985			933	1,361	1,647	2,219	6.34	10.34	1,186
	Minimum	454			201	379	498	736			
	End	640			122	424	626	1,028			

OUTPUT TORQUE DATA (CONTINUED)

The torque values above indicate the actual actuator output torque. Some values may exceed the max rating of the actuator.

		SPRING RETURN (N-m)							Normal Operation bar	Max MAWP bar	Max Rated Torque N-m*
Left Hand (FAIL CLOSE)	SPRINGS	3 bar	4 bar	5.5 bar	7 bar	8 bar	10 bar				
SR06-S19	Start	210	979	1,361	1,933	2,505	2,886	3,648	1.38	10.34	1,582
	Minimum	103	382	544	787	1,030	1,192	1,516			
	End	164	595	864	1,266	1,669	1,937	2,474			
SR06-S27	Start	309	884	1,266	1,838	2,409	2,791	3,553	2.07	10.34	1,582
	Minimum	156	331	494	737	981	1,143	1,468			
	End	259	496	764	1,167	1,570	1,838	2,375			
SR06-S34	Start	403	861	1,242	1,814	2,386	2,767	3,530	2.76	10.34	1,582
	Minimum	191	290	450	691	931	1,091	1,412			
	End	283	402	671	1,074	1,476	1,745	2,282			
SR06-S36	Start	436	847	1,229	1,801	2,373	2,754	3,516	2.76	10.34	1,582
	Minimum	204	274	434	673	913	1,072	1,391			
	End	296	369	638	1,040	1,443	1,711	2,248			
SR06-S37	Start	423	789	1,170	1,742	2,314	2,695	3,458	2.76	10.34	1,582
	Minimum	213	274	436	680	923	1,086	1,410			
	End	355	382	650	1,053	1,456	1,724	2,261			
SR06-S52	Start	613	697	1,078	1,650	2,222	2,603	3,365	4.14	10.34	1,582
	Minimum	294	188	349	590	831	992	1,313			
	End	447	192	461	863	1,266	1,534	2,071			
SR06-S55	Start	647	683	1,064	1,636	2,208	2,589	3,352	4.14	10.34	1,582
	Minimum	308	174	334	575	816	976	1,297			
	End	461	159	427	830	1,233	1,501	2,038			
SR06-S56	Start	630	612	993	1,565	2,137	2,518	3,281	4.14	10.34	1,582
	Minimum	318	170	332	576	820	983	1,308			
	End	532	176	444	847	1,250	1,518	2,055			
SR06-S62	Start	712	601	983	1,555	2,126	2,508	3,270	4.14	10.34	1,582
	Minimum	347	137	298	539	781	942	1,264			
	End	542	93	362	764	1,167	1,435	1,972			
SR06-S64	Start	837		1,130	1,702	2,274	2,655	3,417	4.83	10.34	1,582
	Minimum	348		264	493	723	876	1,182			
	End	395		236	639	1,042	1,310	1,847			
SR06-S65	Start	746	588	969	1,541	2,113	2,494	3,257	4.83	10.34	1,582
	Minimum	360	123	284	526	768	929	1,251			
	End	556	60	328	731	1,133	1,402	1,939			
SR06-S71	Start	826		887	1,459	2,031	2,412	3,175	4.83	10.34	1,582
	Minimum	404		241	483	725	886	1,209			
	End	638		248	650	1,053	1,321	1,858			
SR06-S73	Start	840		829	1,400	1,972	2,354	3,116	5.52	10.34	1,582
	Minimum	421		227	471	714	876	1,201			
	End	697		234	637	1,039	1,308	1,845			
SR06-S74	Start	860		874	1,446	2,018	2,399	3,161	5.52	10.34	1,582
	Minimum	418		227	469	711	872	1,194			
	End	651		214	617	1,019	1,288	1,825			
SR06-S84	Start	939		733	1,305	1,877	2,259	3,021	6.21	10.34	1,582
	Minimum	474		176	420	664	827	1,152			
	End	792		135	538	940	1,209	1,746			
SR06-S93	Start	1,053		638	1,210	1,782	2,163	2,925	6.41	10.34	1,582
	Minimum	531		119	362	606	769	1,094			
	End	887		21	424	826	1,095	1,632			

2200

OUTPUT TORQUE DATA (CONTINUED)

The torque values above indicate the actual actuator output torque. Some values may exceed the max rating of the actuator.

		SPRING RETURN (N-m)							Normal Operation bar	Max MAWP bar	Max Rated Torque N-m*	
Left Hand (FAIL CLOSE)		SPRINGS	3 bar	4 bar	5.5 bar	7 bar	8 bar	10 bar				
2250	SR08-S03	Start	555	2,139	3,036	4,382	5,728	6,625	8,419	2.07	10.34	3,164
		Minimum	283	820	1,188	1,740	2,292	2,660	3,396			
		End	552	1,340	1,971	2,919	3,866	4,498	5,761			
	SR08-S31	Start	861	1,854	2,751	4,097	5,443	6,340	8,134	2.76	10.34	3,164
		Minimum	436	667	1,035	1,586	2,138	2,505	3,240			
		End	837	1,034	1,666	2,614	3,561	4,193	5,456			
	SR08-S02	Start	1,252	1,463	2,360	3,705	5,051	5,948	7,742	3.45	10.34	3,164
		Minimum	636	467	835	1,387	1,938	2,306	3,042			
		End	1,229	643	1,274	2,222	3,169	3,801	5,064			
SR08-S21	Start	1,291	1,408	2,305	3,650	4,996	5,893	7,687	4.14	10.34	3,164	
	Minimum	659	445	813	1,365	1,917	2,285	3,021				
	End	1,284	604	1,235	2,183	3,130	3,762	5,025				
SR08-S01	Start	1,808	911	1,808	3,153	4,499	5,396	7,190	5.45	10.34	3,164	
	Minimum	920	184	552	1,103	1,655	2,023	2,759				
	End	1,781	87	719	1,666	2,614	3,245	4,509				
SR08-S11	Start	2,152		1,468	2,813	4,159	5,056	6,850	5.86	10.34	3,164	
	Minimum	1,095		376	928	1,480	1,847	2,583				
	End	2,121		375	1,322	2,270	2,901	4,165				
2250	SR10-S03	Start	1,252	2,977	4,378	6,481	8,583	9,985		2.76	8.27	3,164
		Minimum	636	1,088	1,663	2,525	3,387	3,961				
		End	1,229	1,708	2,695	4,176	5,656	6,643				
	SR10-S02	Start	1,808	2,424	3,826	5,929	8,031	9,433		4.14	8.27	3,164
		Minimum	920	805	1,379	2,241	3,103	3,678				
		End	1,781	1,153	2,140	3,620	5,101	6,088				
	SR10-S01	Start	2,640	1,598	2,999	5,102	7,204	8,606		4.07	8.27	3,164
		Minimum	1,344	380	955	1,817	2,679	3,254				
		End	2,608	321	1,308	2,789	4,269	5,256				

OUTPUT TORQUE DATA (CONTINUED)

The torque values above indicate the actual actuator output torque. Some values may exceed the max rating of the actuator.

SPRING RETURN (N-m)								Normal Operation bar	Max MAWP bar	Max Rated Torque N-m*	
Left Hand (FAIL CLOSE)	SPRINGS	3 bar	4 bar	5.5 bar	7 bar	8 bar					
2300	SR12-S04	Start	2,926	4,574	6,996	10,630	14,263	16,685	3.45	8.27	6,327
		Minimum	1,452	1,519	2,509	3,994	5,480	6,470			
		End	2,693	2,190	3,895	6,454	9,012	10,717			
2300	SR12-S03	Start	3,333	4,199	6,622	10,255	13,888	16,310	3.45	8.27	6,327
		Minimum	1,654	1,317	2,307	3,793	5,278	6,269			
		End	3,067	1,783	3,488	6,047	8,605	10,310			
2300	SR12-S02	Start	4,208	3,394	5,817	9,450	13,083	15,506	4.14	8.27	6,327
		Minimum	2,089	882	1,872	3,358	4,843	5,833			
		End	3,872	908	2,614	5,172	7,730	9,435			
2300	SR12-S01	Start	5,234		4,873	8,506	12,139	14,562	4.55	8.27	6,327
		Minimum	2,598		1,364	2,849	4,334	5,325			
		End	4,816		1,588	4,146	6,704	8,410			
2375	SR16-S05	Start	3,885	12,008	17,391	25,465	33,539	38,922	2.07	8.27	12,654
		Minimum	2,035	4,608	6,822	10,144	13,466	15,680			
		End	4,140	7,485	11,275	16,960	22,645	26,434			
2375	SR16-S04	Start	5,312	10,487	15,870	23,944	32,018	37,401	2.76	8.27	12,654
		Minimum	2,783	3,860	6,075	9,397	12,719	14,933			
		End	5,661	6,058	9,848	15,532	21,217	25,007			
2375	SR16-S03	Start	5,946	9,811	15,194	23,268	31,342	36,725	3.45	8.27	12,654
		Minimum	3,116	3,527	5,742	9,063	12,384	14,599			
		End	6,337	5,423	9,213	14,898	20,583	24,373			
2375	SR16-S02	Start	7,135	8,544	13,927	22,001	30,075	35,458	3.45	8.27	12,654
		Minimum	3,738	2,904	5,118	8,439	11,761	13,975			
		End	7,604	4,235	8,024	13,709	19,394	23,184			
2375	SR16-S01	Start	9,197	6,348	11,730	19,804	27,878	33,261	4.14	8.27	12,654
		Minimum	4,819	1,822	4,036	7,356	10,677	12,891			
		End	9,801	2,173	5,963	11,648	17,333	21,123			

OUTPUT TORQUE DATA (CONTINUED)

The torque values above indicate the actual actuator output torque. Some values may exceed the max rating of the actuator.

SPRING RETURN (N-m)								Normal Operation bar	Max MAWP bar	Max Rated Torque N-m*
Left Hand (FAIL CLOSE)	SPRINGS	3 bar	4 bar	5.5 bar	7 bar	8 bar				
SR16-S03	Start	8,499	12,833	19,830	30,327	40,823	47,820	3.45	8.27	31,636
	Minimum	4,283	4,315	7,181	11,480	15,779	18,645			
	End	8,160	6,281	11,208	18,599	25,989	30,916			
2488 SR16-S02	Start	11,476	9,297	16,295	26,791	37,287	44,285	4.14	8.27	31,636
	Minimum	5,911	2,709	5,582	9,892	14,202	17,076			
	End	11,695	3,305	8,231	15,622	23,012	27,939			
SR16-S01	Start	19,975			18,631	29,128	36,125	7.31	8.27	31,636
	Minimum	10,194			5,588	9,892	12,762			
	End	19,855			7,123	14,513	19,440			
SR20-S03	Start	8,499	24,641	35,575	51,975	68,376	79,309	2.07	8.27	31,636
	Minimum	4,283	9,156	13,635	20,354	27,073	31,553			
	End	8,160	14,596	22,294	33,841	45,388	53,087			
2488 SR20-S02	Start	11,476	21,105	32,039	48,439	64,840	75,773	2.76	8.27	31,636
	Minimum	5,911	7,556	12,045	18,778	25,512	30,001			
	End	11,695	11,619	19,317	30,864	42,412	50,110			
SR20-S01	Start	19,975	12,946	23,879	40,280	56,680	67,614	4.69	8.27	31,636
	Minimum	10,194	3,258	7,742	14,468	21,193	25,677			
	End	19,855	3,120	10,818	22,365	33,912	41,611			

OUTPUT TORQUE DATA (CONTINUED)

The torque values above indicate the actual actuator output torque. Some values may exceed the max rating of the actuator.

SPRING RETURN (N-m)								Normal Operation bar	Max MAWP bar	Max Rated Torque N-m*
Left Hand (FAIL CLOSE)	SPRINGS	3 bar	4 bar	5.5 bar	7 bar	8 bar				
SR20-S04	Start	21,980	18,300	31,196	50,540	69,884	82,780	4.14	8.27	79,089
	Minimum	10,940	4,886	10,161	18,074	25,987	31,262			
	End	20,388	5,260	14,340	27,960	41,580	50,660			
SR20-S03	Start	27,875		26,030	45,374	64,718	77,614	5.52	8.27	79,089
	Minimum	13,817		7,270	15,178	23,086	28,357			
	End	25,554		8,445	22,065	35,685	44,765			
SR20-S02	Start	30,598		22,702	42,046	61,390	74,286	6.21	8.27	79,089
	Minimum	15,324		5,787	13,703	21,620	26,898			
	End	28,882		5,722	19,342	32,962	42,042			
SR20-S01	Start	40,227			33,516	52,860	65,756	7.58	8.27	79,089
	Minimum	20,040			8,972	16,884	22,159			
	End	37,412			9,713	23,333	32,413			
SR24-S06	Start	27,875	30,157	48,727	76,583	104,438	123,008	4.14	8.27	79,089
	Minimum	13,817	8,957	16,548	27,934	39,321	46,912			
	End	25,554	11,350	24,425	44,038	63,651	76,726			
SR24-S05	Start	30,598	26,829	45,399	73,254	101,110	119,680	4.14	8.27	79,089
	Minimum	15,324	7,478	15,079	26,480	37,881	45,482			
	End	28,882	8,627	21,702	41,315	60,928	74,003			
SR24-S04	Start	40,227		36,869	64,725	92,580	111,150	5.52	8.27	79,089
	Minimum	20,040		10,346	21,740	33,135	40,732			
	End	37,412		12,074	31,687	51,299	64,374			
SR24-S03	Start	46,820		29,477	57,332	85,188	103,758	6.21	8.27	79,089
	Minimum	23,565		6,854	18,261	29,668	37,273			
	End	44,804		5,481	25,093	44,706	57,781			
SR24-S02	Start	49,543		26,149	54,004	81,860	100,430	6.83	8.27	79,089
	Minimum	25,072		5,367	16,782	28,196	35,806			
	End	48,132		2,758	22,371	41,983	55,058			
SR24-S01	Start	59,171			45,474	73,330	91,900	7.31	8.27	79,089
	Minimum	29,788			12,036	23,442	31,046			
	End	56,662			12,742	32,355	45,430			

PARTS DIAGRAM & MATERIALS OF CONSTRUCTION - DOUBLE ACTING

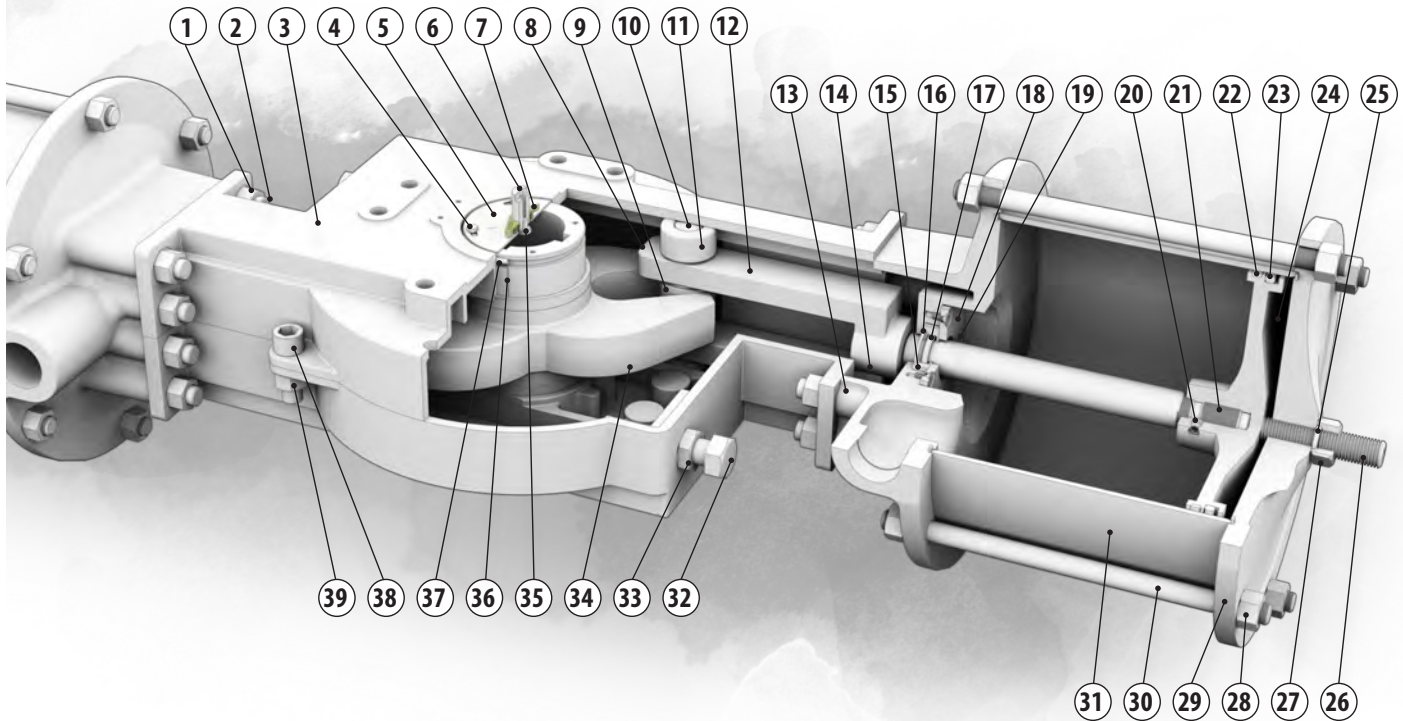

Item No.	Part Description	Material (FS)	Material (FD)
1	Stud Hex Nut	304 SST	304 SST
2	Stud	304 SST	304 SST
3	Body	CF8 SST	Ductile Iron ²
4	Top Hat Base Bolt	304 SST	304 SST
5	Top Hat Base	304 SST	304 SST
6	Top Hat	316 SST Pm	316 SST Pm
7	Top Hat Indicator	Nylon 6/6 GF30	Nylon 6/6 GF30
8	Clevis Pin Set Screw	304 SST	304 SST
9	Yoke Roller	304 SST NIT	304 SST NIT
10	Clevis Pin	304 SST NIT	304 SST NIT
11	Body Roller	304 SST NIT	304 SST NIT
12	Clevis	CF8 SST	Ductile Iron ²
13	Base Plate	CF8 SST	Ductile Iron ²
14	Clevis Set Screw	304 SST	304 SST
15	Seal Carrier	Option ¹	Option ¹
16	Carrier Float Seal	Option ¹	Option ¹
17	Carrier Rod Seal	Option ¹	Option ¹
18	Carrier Retainer	304 SST	304 SST
19	Carrier Retainer Screw	304 SST	304 SST
20	Piston Set Screw	304 SST	304 SST

Item No.	Part Description	Material (FS)	Material (FD)
21	Piston Bolt	304 SST	304 SST
22	Wiper Ring	Option ¹	Option ¹
23	Piston Seal	Option ¹	Option ¹
24	Piston	CF8 SST	Ductile Iron ²
25	Travel Stop Seal	Option ¹	Option ¹
26	End Cap Travel Stop	304 SST	304 SST
27	Travel Stop Nut	304 SST	304 SST
28	Tie Rod Hex Nut	304 SST	304 SST
29	End Cap	CF8 SST	Ductile Iron ²
30	Tie Rod	304 SST	304 SST
31	Cylinder	304 SST ¹	Black Amalgon ¹
32	Body Travel Stop	304 SST	304 SST
33	Body Travel Stop Nut	304 SST	304 SST
34	Yoke	CF8 SST	Ductile Iron ²
35	Top Hat Bolt	304 SST	Ductile Iron ²
36	Yoke Seal	Option ¹	Option ¹
37	Yoke Bushing	Option ¹	Option ¹
38	Body Fastening Nut	304 SST	304 SST
39	Body Fastening Bolt	304 SST	304 SST

1: "Option" materials depend on trim code, see engineering string.

2: Ductile iron components are coated or plated for corrosion resistance.

304 or CF8 stainless steel may be upgraded to 316 or CF8M stainless steel based on availability or customer request. Materials shown are standard. Other materials available, contact QTRCO for special options. Special coatings, plating, or surface treatments are also available

PARTS DIAGRAM & MATERIALS OF CONSTRUCTION - SPRING RETURN

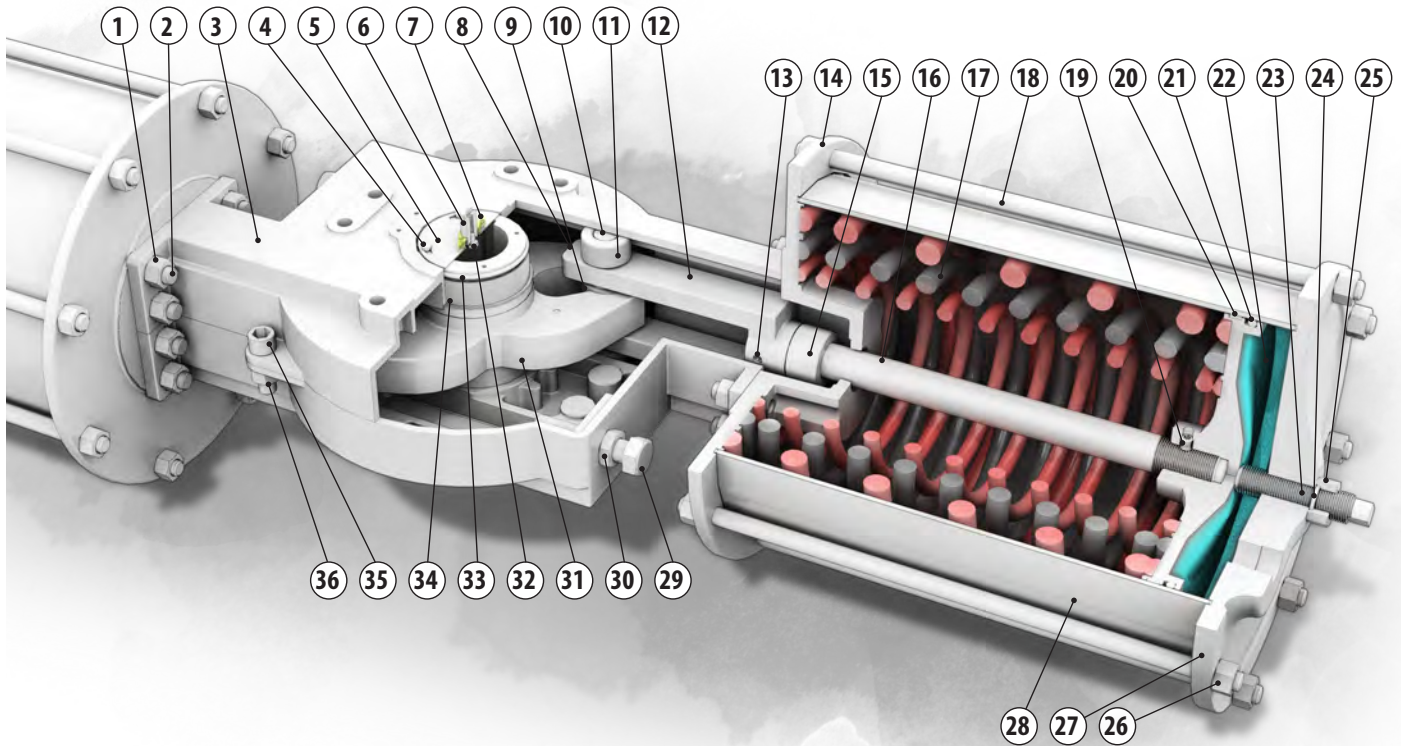

Item No.	Part Description	Material (FS)	Material (FD)
1	Stud Hex Nut	304 SST	304 SST
2	Stud	304 SST	304 SST
3	Body	CF8 SST	Ductile Iron ³
4	Top Hat Base Bolt	304 SST	304 SST
5	Top Hat Base	304 SST	304 SST
6	Top Hat	316 SST PM	316 SST PM
7	Top Hat Indicator	Nylon 6/6 Gf30	Nylon 6/6 Gf30
8	Clevis Pin Set Screw	304 SST	304 SST
9	Yoke Roller	304 SST NIT	304 SST NIT
10	Clevis Pin	304 SST NIT	304 SST NIT
11	Body Roller	304 SST NIT	304 SST NIT
12	Clevis	CF8 SST	Ductile Iron ³
13	Clevis Set Screw	304 SST	304 SST
14	Spring Retainer	CF8 SST	304 SST
15	Safety Collar	304 SST	304 SST
16	Piston Bolt	304 SST	304 SST
17	Springs	Chrome Silicon ¹	Chrome Silicon ¹
18	Tie Rod	304 SST	304 SST

Item No.	Part Description	Material (FS)	Material (FD)
19	Piston Set Screw	304 SST	304 SST
20	Wiper Ring	Option ²	Option ²
21	Piston Seal	Option ²	Option ²
22	Piston	CF8 SST	Ductile Iron ³
23	End Cap Travel Stop	304 SST	304 SST
24	Travel Stop Seal	Option ²	Option ²
25	End Cap Travel Stop Nut	304 SST	304 SST
26	Tie Rod Hex Nut	304 SST	304 SST
27	End Cap	CF8 SST	Ductile Iron ³
28	Cylinder	304 SST ²	Black Amalgon ²
29	Body Travel Stop	304 SST	304 SST
30	Body Travel Stop Nut	304 SST	304 SST
31	Yoke	CF8 SST	Ductile Iron ³
32	Top Hat Bolt	304 SST	304 SST
33	Yoke Seal	Option ²	Option ²
34	Yoke Bushing	Option ²	Option ²
35	Body Fastening Bolt	304 SST	304 SST
36	Body Fastening Nut	304 SST	304 SST

1: Chrome Silicon springs are powder coated. Stainless Steel springs available.

2: "Option" materials depend on trim code, see engineering string.

304 or CF8 stainless steel may be upgraded to 316 or CF8M stainless steel based on availability or customer request. Materials shown are standard. Other materials available, contact QTRCO for special options. Special coatings, plating, or surface treatments are also available

3: Ductile iron components are coated or plated for corrosion resistance.

ENGINEERING STRING For ordering actuators with standard options and trim, specify items 1-8 and 16 as applicable. QTRCO will choose the appropriate trim.

1	2	3	4	5	6	7	8	9	10	11	12	13	14	15	16	17	18
---	---	---	---	---	---	---	---	---	----	----	----	----	----	----	----	----	----

Model (1)	Action (4)	PST/SZ Angle (5)	Temp Limits (8)	O-Rings (13)	Options (17) Separate multiple options with a comma
FS Stainless Steel FD Ductile Iron	Replace xx with piston size according to torque tables. DAXX* Double Acting SRXX* Spring Return, Fail to 0 or 90 degrees SYXX Spring Return, Fail to 45 degrees	Axx SP actuators: Angle of travel as measured from the piston fully inward position that valve will be allowed to travel during partial stroke test. SZ actuators: Angle (from fully CCW position) of fail position for SZ actuator. Example: for an SZ actuator that travels 30deg CW and 60 degrees CCW, this field would be A30	T Custom Range Q -76°F to 310°F G -60F to 185F M* -20F to 185F H -20F to 400F	40 Custom 41* Buna N 42 Viton 43 Silicon 44 EPDM	JR Jackscrew. Handwheel size and material specified separately. HRxxxx Hydraulic override, cylinders only. Pump and reservoir specified separately. xxxx is defined by QTRCO to specify the cylinder size. ETSxx.yy XX: Travel Adjustment End Cap Side YY: Travel Adjustment Body Side Example: 15.80 (65 degrees total travel): A spring return actuator would fail to a 15 degree position in both LH and RH (fail-open or fail-closed) models, and would stroke with pressure to an 80 degree position (65 degrees total travel). An LH double acting model would stroke clockwise to the 15 degree position, and counter clockwise to the 80 degree position. IPxx Special Ingress Protection (IP) rating. Replace xx with rating required. Rating certificate will be provided.
Grade (2)	SZXX Spring Return, Fail to other angles SPAXX Spring Return with partial stroke (Xrciser) add-on. Replace 'a' with number of partial stroke positions (standard is 1) SEAXX Spring Return with tandem cylinders to assist spring compression. Replace 'a' with number of tandem pistons (Standard is 2, must be multiples of 2)				
Size (3)	SPAEbxx Spring Return with partial stroke (Xrciser) add-on and tandem cylinders to assist spring compression. Replace 'a' with number of partial stroke positions (standard is 1). Replace 'b' with number of tandem pistons (Standard is 2, must be multiples of 2) DPAxx Double Acting with partial stroke (Xrciser) add-on. Replace 'a' with number of partial stroke positions (standard is 1)				
2100 2150 2200 2250 2300 2375 2488 2575					
Spring Set (6)	Bushings (11)	Orientation (16)			
Sxx Choose spring set based on required torque (N/A for DA and DP models).	20 Custom 21* Acetal ² 22* Bronze Filled PTFE 23 PEEK 24 Carbon Filled PTFE	LH* Left Hand. Pistons move outward to turn the valve clockwise. This is commonly called "Fail Closed" for spring return actuators. RH Right Hand. Pistons move outward to turn the valve counterclockwise. This is commonly called "Fail Open" for spring return actuators.			
Port Size (7)	Wiper Rings (12)				
P00 Custom P01* 1/4 NPT P02 3/8 NPT P03 1/2 NPT P04 3/4 NPT P05 1 NPT P06 1 1/4 NPT P07 1 1/2 NPT P08 2 NPT P09 2 1/2 NPT P10 3 NPT P11 4 NPT	30 Custom 31* PTFE 32 UHMWPE				
		Modifier (18)			
		3-digit number used by QTRCO to identify further customization. Contact QTRCO for details.			
		Pressure Equipment Directive (19)			
		SEP Actuator will be provided based on SEP with appropriate documentation PED Actuator will be provided as fully PED compliant			

NOTES: * items are considered standard Ensure material compatibility of all components with applications requirements.
(7) Port size limited by piston size.

PISTON SIZE (IN)	4	6	8	10	12	16	20	24
Pmax	P04	P05	P05	P07	P09	P10	P10	P11

(8) Environmental temperature requirements may limit the use of certain trim materials. Temperature ranges may be extended with proper insulation. Ductile iron units may be used in low temperature (less than -20F), but stroke speed should be limited to prevent brittle fracture. Allowable temperature on SP units may be limited by selected sensors (specified separately).

(9) Standard springs are various grades of spring steel, most commonly chrome silicon, with powder coat.

(15) QTRCO selects the appropriate grease based on application requirements.

(17) Multiple compatible options may be chosen. Separate options with a comma

(18) This number is assigned by QTRCO for modifications that cannot be defined by the engineering string. Contact QTRCO for details about specific modifiers.

(19) Omit if not required. The European Pressure Equipment Directive (PED, 2014/68/EU) requires equipment to be placed in categories based on Fluid Group and Bar Liter rating. The End User must report the intended Fluid Group to QTRCO at the time of order to ensure proper PED category determination. Models that are smaller than the minimum PED bar-liter rating are prohibited by the PED from being marked or listed as conforming. Those sizes will be sold under SEP, compliant by exemption, and are still qualified to be sold into the EU market.

ENGINEERING STRING For ordering actuators with standard options and trim, specify items 1-8 and 16 as applicable. QTRCO will choose the appropriate trim.

SAMPLE SPECIFICATIONS	DESCRIPTION
FSCxxxSRxx-S06-P01-M-11-S-21-31-41-51-61-LH	Standard stainless SR actuator with medium temp trim.
FDCxxxDAxx-P01-G-A-21-31-43-51-61-LH	Standard ductile iron DA actuator with low temp trim.
FDCxxxSRxx-S02-P01-H-11-L-22-31-42-51-61-LH	Standard ductile iron SR actuator with high temp trim.
FDCxxxSP1xx-A15-S10-P04-G-11-A-21-31-43-51-61-LH	Ductile iron, 1 position partial stroke at 15degrees, 3/4" NPT ports, standard low temp trim.
FSCxxxSRxx-S04-P01-M-11-S-22-31-42-51-61-LH	Stainless, medium temp trim.
FDCxxxDAxx-P01-H-11-L-22-31-42-51-61-LH-SEP	Ductile iron, high temp trim, SEP documentation required.
FSNxxxSRxx-S03-P01-M-12-S-23-33-44-52-63-RH-HR	Stainless, nuclear grade with medium temp nuclear trim and stainless springs. Right hand (fail open) orientation with hydraulic override.
FDCxxxSP1xx-A15-S40-P04-G-12-S-24-31-43-51-62-LH-HR3001,ETS22.90,IP69K-PED	Ductile iron, 1 position partial stroke at 15degrees, 3/4" NPT ports, low temp trim stainless springs and cylinders, carbon filled PTFE bushings, food grade grease, hydraulic override code number 3001, extended travel stops that allow the actuator to fail at a 22 degree position and travel fully to the opposite position, IP69K rating required, full PED compliance required.

F

SERIES

QTRCO, INC. PRODUCT BULLETIN

F

SERIES

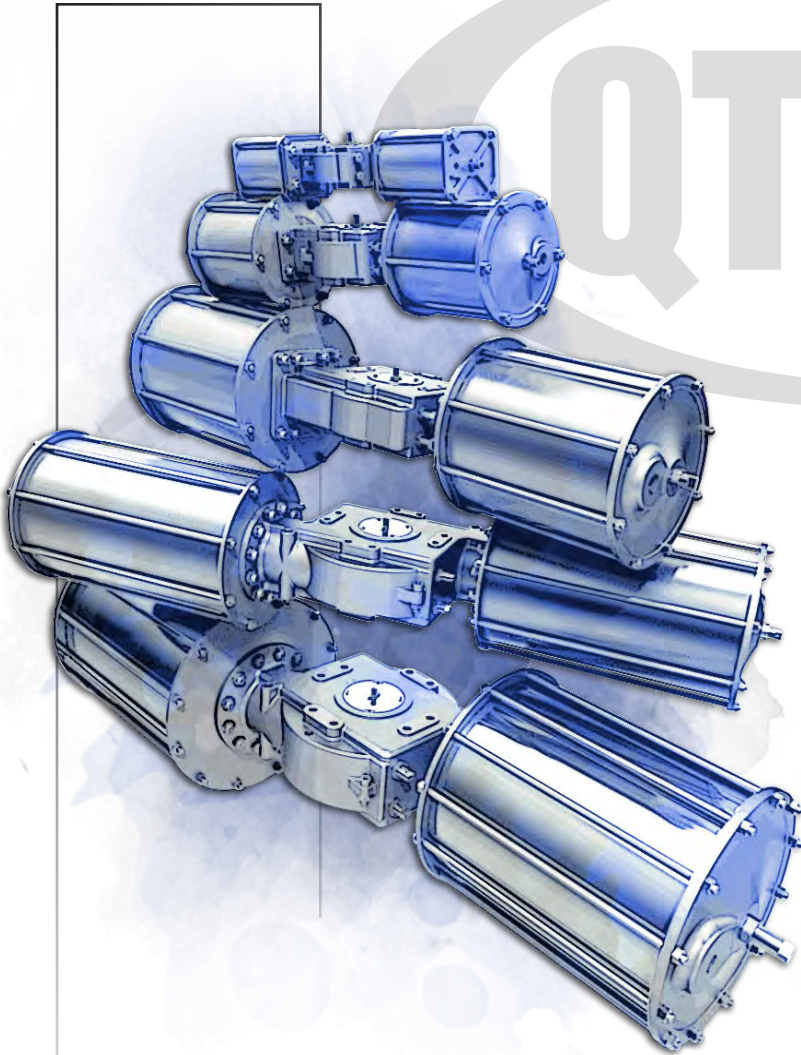

QTRCO

The Leader in Actuator Technology

QTRCO, Inc. | phone (281) 516-0277
13120 Theis Lane • Tomball, TX 77375 USA

 **888.ACTU.8.IT**
888.228.8848

 **www.qtrco.com**
Email: actu8it@qtrco.com

DCN00651(23)