

In this view, applying pressure to the end cap port will compress the springs and push the piston inward causing counter-clockwise rotation of the shaft. This is typical for a 'fail closed' application. Turn the actuator 'top side down' to reverse the action.

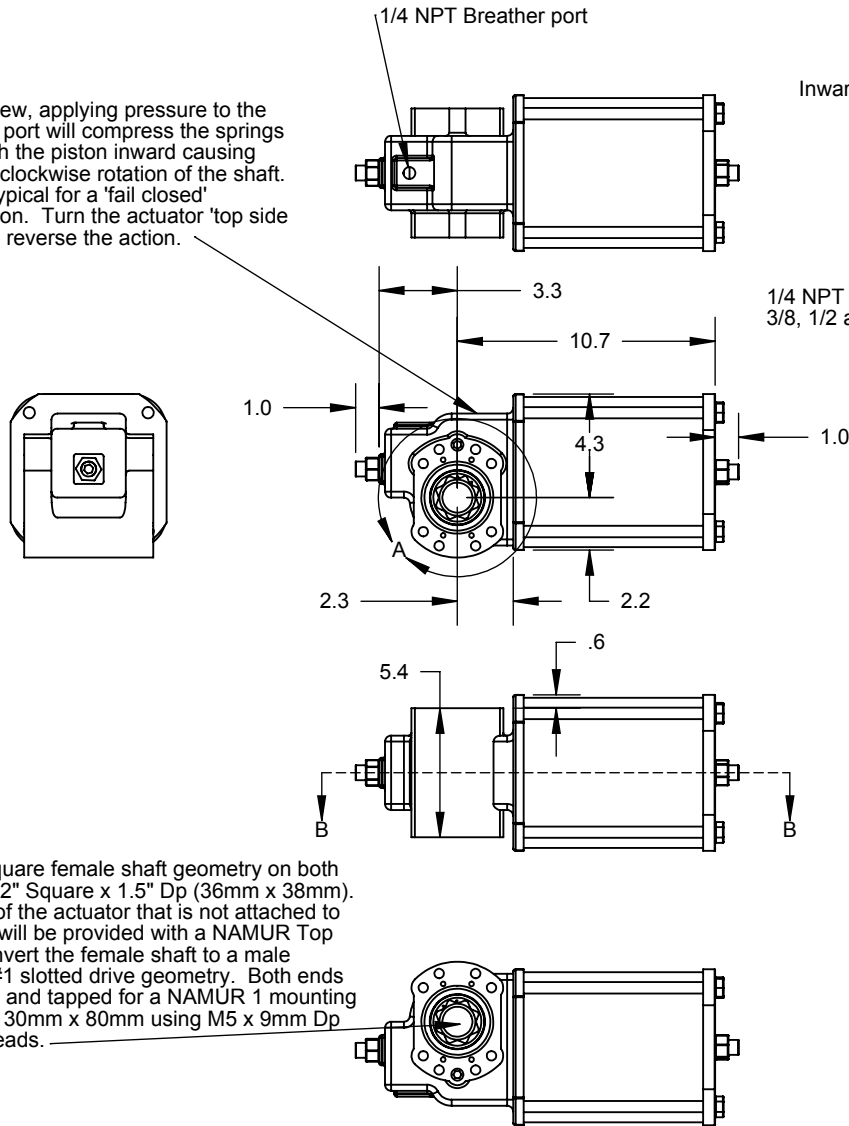

Double square female shaft geometry on both ends. 1.42" Square x 1.5" Dp (36mm x 38mm). The side of the actuator that is not attached to the valve will be provided with a NAMUR Top Hat to convert the female shaft to a male NAMUR #1 slotted drive geometry. Both ends are drilled and tapped for a NAMUR 1 mounting pattern or 30mm x 80mm using M5 x 9mm Dp screw threads.

Inward travel stop

SECTION B-B
SCALE 1 : 4

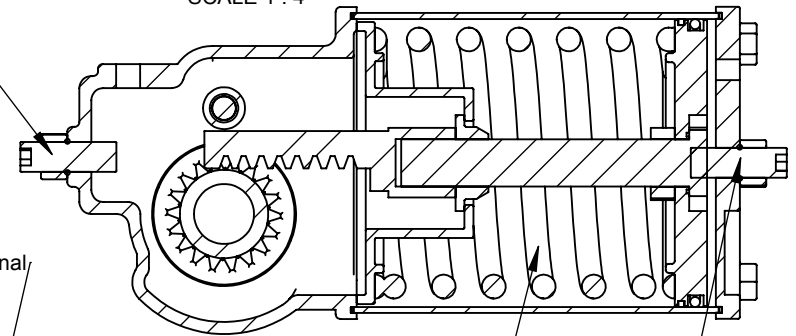

1/4 NPT Pressure port
3/8, 1/2 and 3/4 NPT optional

Captured springs

Outward travel stop

8 Threaded mounting holes both ends
M10-1.5 x 0.6" Deep
4 on 4.02" BCD
4 on 1.5 x 4.02 Rectangular pattern

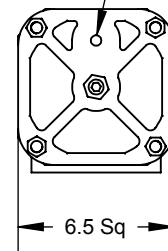

DETAIL A
SCALE 1 : 4

In this view, the shaft is shown over-rotated prior to travel stop adjustment.

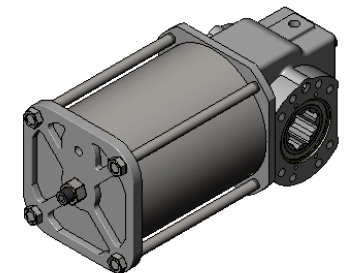

DIMENSIONS ARE IN INCHES
TOLERANCES except as shown
FRACTIONAL: ±
ANGULAR: ±
2 PLACE DECIMAL: ±
3 PLACE DECIMAL: ±

	NAME	DATE
DRAWN	EH	1/12/09
Rev B		
Rev C		
Rev D		
Rev E		

QTRCO, Inc.

QS07SR and QS07SR
Dimensions

PROPRIETARY AND CONFIDENTIAL
THE INFORMATION CONTAINED IN THIS DRAWING IS THE SOLE PROPERTY OF QTRCO, INC. ANY REPRODUCTION IN PART OR AS A WHOLE WITHOUT THE WRITTEN PERMISSION OF QTRCO, INC. IS PROHIBITED.

MATERIAL
PROCESS
DO NOT SCALE DRAWING

SIZE **A** DWG. NO. **QS07SR-DIM-001A**

WEIGHT (Pounds): **47**

SHEET ____ OF ____
1 of 1 if not shown