

DETAIL A
SCALE 1 : 4

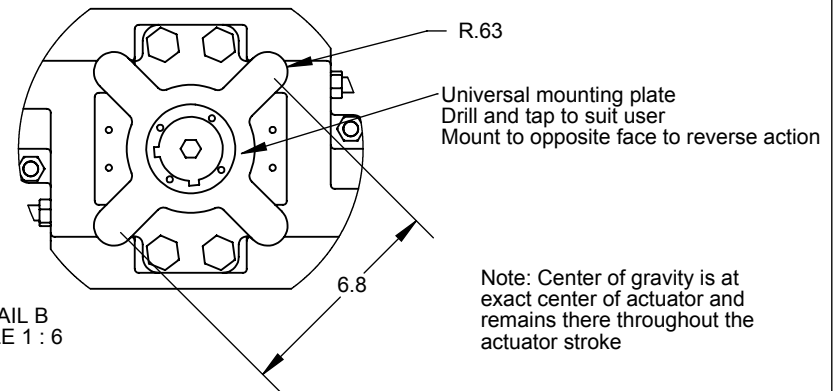
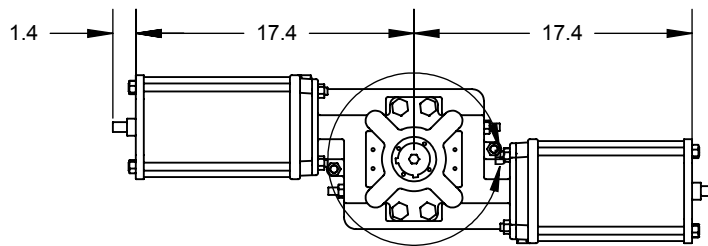
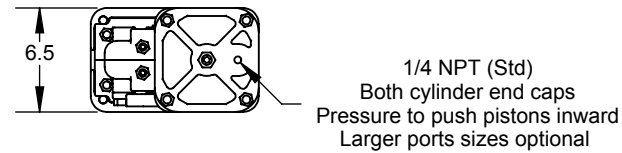
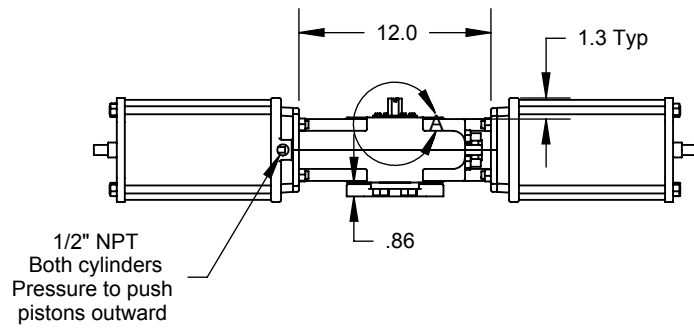
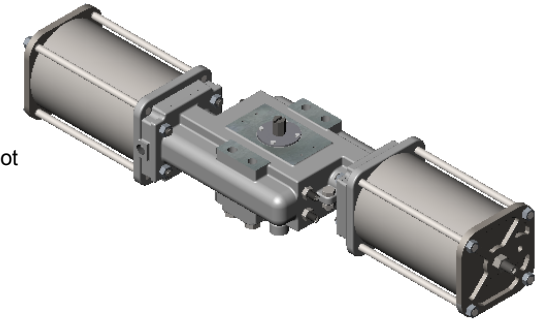

DETAIL B
SCALE 1 : 6

DIMENSIONS ARE IN INCHES TOLERANCES except as shown FRACTIONAL: ± ANGULAR: ± 2 PLACE DECIMAL: ± 3 PLACE DECIMAL: ±		NAME	DATE	QTRCO, Inc.	
MATERIAL		DRAWN	EH 6/20/10		Dimensional Drawing F200DA06
PROCESS		Rev B			
DO NOT SCALE DRAWING		Rev C			SIZE A DWG. NO. F200DA06-DIM-01A
PROPRIETARY AND CONFIDENTIAL THE INFORMATION CONTAINED IN THIS DRAWING IS THE SOLE PROPERTY OF QTRCO, INC. ANY REPRODUCTION IN PART OR AS A WHOLE WITHOUT THE WRITTEN PERMISSION OF QTRCO, INC. IS PROHIBITED.		Rev D			
		Rev E		SHEET ____ OF ____ 1 of 1 if not shown	