

17 Clearance required for cylinder removal and seal replacement - Both ends

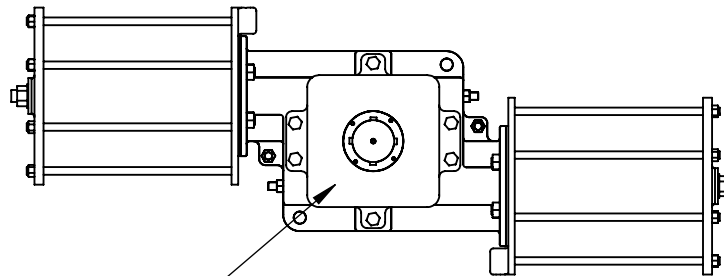
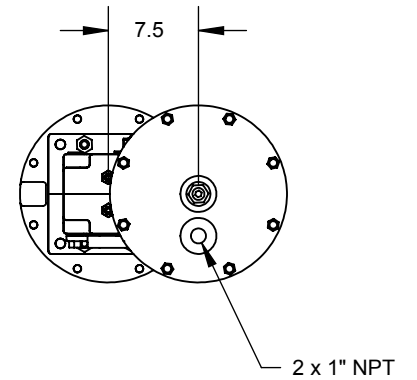
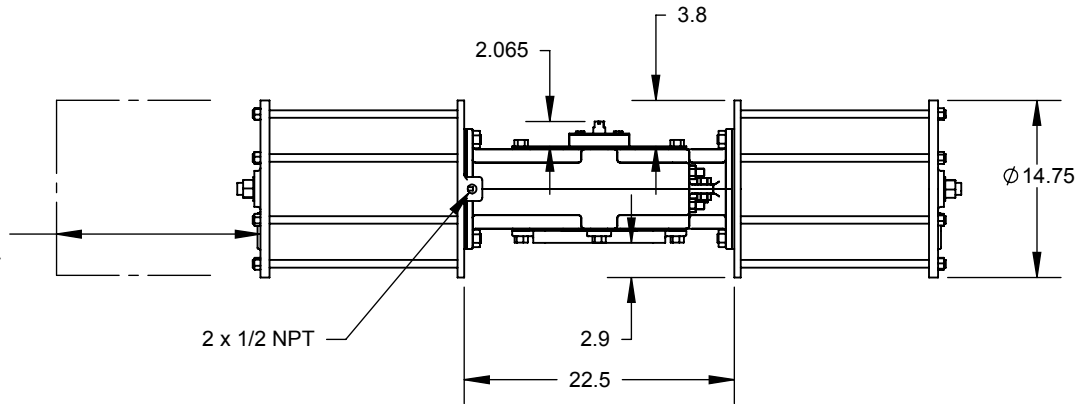

Universal Mounting Plate
Mounting pattern to suit application

DIMENSIONS ARE IN INCHES
TOLERANCES except as shown
FRACTIONAL: ±
ANGULAR: ±
2 PLACE DECIMAL: ±
3 PLACE DECIMAL: ±

	NAME	DATE
DRAWN	EH	7/16/08
Rev B		
Rev C		
Rev D		
Rev E		

QTRCO, Inc.

F375DA12 Complete

PROPRIETARY AND CONFIDENTIAL

THE INFORMATION CONTAINED IN THIS DRAWING IS THE SOLE PROPERTY OF QTRCO, INC. ANY REPRODUCTION IN PART OR AS A WHOLE WITHOUT THE WRITTEN PERMISSION OF QTRCO, INC. IS PROHIBITED.

MATERIAL
PROCESS
DO NOT SCALE DRAWING

SIZE **A** DWG. NO. F375DA12-001A

WEIGHT (Pounds): 522

SHEET ____ OF ____
1 of 1 if not shown